

**KENYA  
WILDLIFE  
SERVICE**



**TENDER FOR THE PROPOSED CONSTRUCTION  
& MAINTENANCE OF THE 20KM WILDLIFE ELECTRIC FENCE AND  
ASSOCIATED WORKS AT MERU N. PARK - (LABOUR CONTRACT)**

**TENDER NO. KWS/OT/B&F/59/2020-2021**

**CLOSING DATE AND TIME:**

**15<sup>TH</sup> JUNE 2021, AT 12:00 NOON**

**DIRECTOR GENERAL  
KENYA WILDLIFE SERVICE  
P. O. BOX 40241 - 00100  
NAIROBI**

**JUNE, 2021**

**PROPOSED CONSTRUCTION & MAINTANANCE OF 20KM WILDLIFE  
ELECTRIC FENCE AT MERU .N. PARK-  
MERU/THARAKA NTHI COUNTIES.**

**TABLE OF CONTENTS**

	<b><u>PAGE</u></b>
SECTION I: INVITATION TO TENDER .....	3
SECTION II: INSTRUCTIONS TO TENDERERS .....	4-17
SECTION III: APPENDIX TO INSTRUCTION TO TENDERERS .....	18-22
SECTION IV: CONDITIONS OF CONTRACT .....	23-45
SECTION V: APPENDIX TO CONDITIONS OF CONTRACT .....	46-48
SECTION VI: STANDARD FORMS .....	48-64
SECTION VII: SPECIFICATIONS.....	65-73
SECTION VIII: PRICING PREAMBLES.....	74
SECTION IX: PRELIMINARIES .....	75-81
SECTION X: BILLS OF QUANTITIES .....	82-85
SECTION XII: PERFORMANCE BASED MAINTENANCE..... CONTRACT (PBC)	86 -140
SECTION XI: DRAWINGS .....	142-144

## SECTION - I

### INVITATION FOR TENDERS

**Tender No. KWS/OT/BF/59/2020-2021**

**PROPOSED CONSTRUCTION & MAINTANANCE OF 10KM WILDLIF  
ELECTRIC FENCE AT MERU .N. PARK-  
MERU/THARAKA NTHI COUNTIES.**

- 1.1 The Director General, Kenya Wildlife Service P.O. Box 40241 Nairobi invites sealed tenders for the proposed construction and Maintenance Of 20km Wildlife Electric fence and Assciated Works at Meru N.Park in Meru/Tharaka Nthi Counties.
- 1.2 Interested eligible candidates may obtain further information and inspect tender document at Office Head Supplies Chain Management, Kenya Wildlife Service headquarters, Langa'ta Road. P.O. Box 40241 Nairobi during normal working hours.
- 1.3 A complete set of tender documents may be obtained by interested eligible candidates for free from the website <http://kws.go.ke>. Bidders who download the tender document from the website must forward their particulars immediately for records and any further tender clarifications and addenda and will not be required to pay any fee.
- 1.4 Prices quoted should **be inclusive of all taxes**, must be in Kenya shillings and shall remain valid for **(90 )** days from the closing date of tender. Bid security shall be valid for **120 days**
- 1.5 Completed tender documents are to be enclosed in plain sealed Envelopes marked with **Tender name and reference number and deposited in the Tender Box** at Main Reception Lobby, ground floor, KWS Headquarters, Langa'ta Road P.O. Box 40241, Nairobi **to be received on or before 15<sup>th</sup> June, 2021 at 12.00noon**. Non compliance to the foregoing rules of submission shall lead to automatic disqualification
- 1.6 Tenders will be opened immediately thereafter in the presence of the candidates or their representatives who choose to attend

**SECTION II**

**INSTRUCTIONS TO TENDERERS**

**TABLE OF CONTENTS PAGE**

<b>CLAUSE</b>		<b>PAGE</b>
1.	General .....	5
2.	Tender Documents .....	8
3.	Preparation of Tenders .....	9
4.	Submission of Tenders .....	11
5.	Tender Opening and Evaluation .....	12
6.	Award of Contract .....	15
7.	Corrupt & Fraudulent practices .....	16
8.	Description of Work.....	16

## **INSTRUCTIONS TO BIDDERS.**

### **A 1. General/Eligibility/Qualifications/Joint venture/Cost of Tendering**

- 1.1 The Employer as defined in the Appendix to Conditions of Contract invites tenders for Works Contract as described in the tender documents. The successful tenderer will be expected to complete the Works by the Intended Completion Date specified in the tender documents.
- 1.2 All tenderers shall provide the Qualification Information, a statement that the tenderer (including all members of a joint venture and subcontractors) is not associated, or has not been associated in the past, directly or indirectly, with the Consultant or any other entity that has prepared the design, specifications, and other documents for the project or being proposed as Project Manager for the Contract. A firm that has been engaged by the Employer to provide consulting services for the preparation or supervision of the Works, and any of its affiliates, shall not be eligible to tender.
- 1.3 All tenderers shall provide in the Form of Tender and Qualification Information, a preliminary description of the proposed work method and schedule, including drawings and charts, as necessary.
- 1.4 All tenderers shall include the following information and documents with their tenders, unless otherwise stated by (The Public Procurement and Asset Disposal Act, 2015 (preference and reservations) where applicable.
  - (a) Copies of original documents defining the constitution or legal status, place of registration, and principal place of business; registration certificate With National Construction Authority as a general building contractor or Civil category **NCA-6 and 5 respectively** or above and specialist contractor (Electrical) category **NCA 5** or above and valid Tax Compliance certificate written power of attorney of the signatory of the tender to commit the tenderer:
  - (b) Total monetary value of construction work performed for each of the last five years:
  - (c) Details of similar major contracts in the last 5yrs, experience as main contractor in the construction of Wildlife electric fences at least two works of a nature and complexity equivalent

to the Works (Kshs. 15 million) over the last 5 years (to comply with this requirement, works cited should be at least 70 percent complete); supported by copies of award letter Signed form of Contract/Agreement.

- (d) Major items of construction equipment proposed to carry out the Contract and an undertaking that they will be available for the Contract.
- (e) Qualifications and experience of key site management and technical personnel (project manager, site agent and foreman) proposed for the Contract and an undertaking that they shall be available for the Contract.
- (f) Reports on the financial standing of the tenderer, such as profit and loss statements and auditor's reports for the past ; OR certified bank statement for the last 24 months immediately preceding tender closing date.
- (g) Evidence of adequacy of working capital for this Contract (access to line(s) of credit and availability of other financial resources);
- (h) Authority to seek references from the tenderer's bankers;
- (i) Information regarding any litigation, current or during the last five years, in which the tenderer is involved, the parties concerned and disputed amount; and
- (j) Proposals for subcontracting components of the Works amounting to more than 10 percent of the Contract Price.

1.5 Tenders submitted by a joint venture of two or more firms as partners shall comply with the following requirements, unless otherwise stated:

- (a) The tender shall include all the information listed in clause 1.5 above for each joint venture partner;
- (b) The tender shall be signed so as to be legally binding on all Partners;
- (c) All partners shall be jointly and severally liable for the execution of the Contract in accordance with the Contract terms;
- (d) One of the partners will be nominated as being in charge, Authorized to incur liabilities, and receive instructions for and on behalf of all partners of the joint venture; and
- (e) The execution of the entire Contract, including payment, shall be done exclusively with the partner in charge.

- 1.6 To qualify for award of the Contract, tenderers shall meet the following minimum qualifying criteria;
- (a) annual volume of construction work of at least 2.0 times the estimated annual cash flow for the Contract;
  - (b) Experience as main contractor in the construction of Wildlife electric fences at least two works of a nature and complexity equivalent to the Works over the last 5 years (to comply with this requirement, works cited should be at least 70 percent complete);
  - (c) Proposals for the timely acquisition (own, lease, hire, etc.) of the essential equipment listed as required for the Works;
  - (d) A project manager, a site agent and foreman each with requisite experience in works of an equivalent nature and volume, besides relevant academic qualifications supported by academic certificates and signed curriculum vitae
  - (e) Liquid assets and/or credit facilities, net of other contractual commitments and exclusive of any advance payments which may be made under the Contract, of no less than 3 months of the estimated payment flow under this Contract.
- 1.7 The figures for each of the partners of a joint venture shall be added together to determine the tenderer's compliance with the minimum qualifying criteria of clause 1.7 (a) and (e); however, for a joint venture to qualify, each of its partners must meet at least 25 percent of minimum criteria 1.7 (a), (b) and (e) for an individual tenderer, and the partner in charge at least 40 percent of those minimum criteria. Failure to comply with this requirement will result in rejection of the joint venture's tender. Subcontractors' experience and resources will not be taken into account in determining the tenderer's compliance with the qualifying criteria, unless otherwise stated.
- 1.8 Each tenderer shall submit only one tender, either individually or as a partner in a joint venture. A tenderer who submits or participates in more than once in same tender either in capacity of director/proprietor in a different company (other than as a subcontractor or in cases of alternatives that have been permitted or requested) will cause all the proposals with the tenderer's participation to be disqualified.
- 1.9 The tenderer shall bear all costs associated with the preparation and submission of his tender, and the Employer will in no case be responsible or liable for those costs.
- 1.10 The tenderer, at the tenderer's own responsibility and risk, is encouraged to visit and examine the Site of the Works and its surroundings, and obtain all information that may be necessary for preparing the tender and entering into a contract for construction of

the Works. The costs of visiting the Site shall be at the tenderer's own expense. No claims arising from non compliance with the foregoing shall be entertained by the employer

- 1.11 The procuring entity's employees, committee members, board members and their relative (spouse and children) are not eligible to participate in the tender.
- 1.12 Contractors who have been issued with a Default Notice or in any termination proceedings for non performance in any Government funded project are ineligible to tender for these works.

## **2. Tender Documents**

- 2.1 The complete set of tender documents comprises the documents listed below and any addenda issued in accordance with Clause 2.4. or such other documents that may be issued by the employer to supplement or compliment the listed documents
  - (a) These Instructions to Tenderers
  - (b) Form of Tender and Qualification Information
  - (c) Conditions of Contract
  - (d) Appendix to Conditions of Contract
  - (e) Specifications
  - (f) Drawings
  - (g) Bills of Quantities
  - (h) Forms of Securities
  - (i) Performance Based Maintenance Contract
- 2.2 The tenderer shall examine all Instructions, Forms to be filled and Specifications in the tender documents. Failure to furnish all information required by the tender documents, or submission of a tender not substantially responsive to the tendering documents in every respect will be at the tenderer's risk and may result in rejection of his tender.
- 2.3 A prospective tenderer making an inquiry relating to the tender documents may notify the Employer in writing or by cable, telex or facsimile at the address indicated in the letter/advert of invitation to tender. The Employer will only respond to requests for clarification received earlier than seven days prior to the deadline for submission of tenders. Copies of the Employer's response will be forwarded to all persons issued with tendering documents, including a description of the inquiry, but without identifying its source.
- 2.4 Before the deadline for submission of tenders, the Employer may modify the tendering documents by issuing addenda. Any addendum thus issued shall be part of the tendering documents and shall be communicated in writing or by cable, telex or facsimile to all tenderers. Prospective tenderers shall acknowledge receipt of each addendum in writing to the Employer.



- 2.5 To give prospective tenderers reasonable time in which to take an addendum into account in preparing their tenders, the Employer shall extend, as necessary, the deadline for submission of tenders, in accordance with Clause 4.2 here below.

### **3. Preparation of Tenders**

- 3.1 All documents relating to the tender and any correspondence shall be in English language.
- 3.2 The tender submitted by the tenderer shall comprise the following:
- (a) These Instructions to Tenderers, Form of Tender, Conditions of Contract, Appendix to Conditions of Contract and Specifications;
  - (b) Tender Security;
  - (c) Priced Bill of Quantities ;
  - (d) Qualification Information Form and Documents;
  - (e) Alternative offers where invited; and
  - (f) Any other materials required to be completed and submitted by the tenderers.
- 3.3 The tenderer shall fill in rates and prices for all items of the Works described in the Bill of Quantities. Items for which no rate or price is entered by the tenderer will not be paid for when executed and shall be deemed covered by the other rates and prices in the Bill of Quantities. All duties, taxes, and other levies payable by the Contractor under the Contract, or for any other cause relevant to the Contract, as of 30 days prior to the deadline for submission of tenders, shall be included in the billed item rates forming tender price submitted by the tenderer.
- 3.4 The rates and prices quoted by the tenderer shall only be subject to adjustment during the performance of the Contract if provided for in the Appendix to Conditions of Contract and provisions made in the Conditions of Contract.
- 3.5 The unit rates and prices shall be in Kenya Shillings.

- 3.6 Tenders shall remain valid for a period of **(90)** days from the date of submission. However in exceptional circumstances, the Employer may request that the tenderers extend the period of validity for a specified additional period. The request and the tenderers' responses shall be made in writing. A tenderer may refuse the request without forfeiting the Tender Security. A tenderer agreeing to the request will not be required or permitted to otherwise modify the tender, but will be required to extend the validity of Tender Security for the period of the extension, and in compliance with Clause 3.7 - 3.11 in all respects.
- 3.7 The tenderer shall furnish, as part of the tender, an original Bid Bond of **Kenya Shillings Two Hundred and Fifty Thousand only (Kshs. 250,000/=)** issued in Kenya Shillings or a freely convertible currency and in the form of bank guarantee, or an insurance guarantee from PPRA approved Insurance Companies and valid for a period of 120 days from the date of tender opening
- 3.8 The format of the Tender Security should be in accordance with the form of Tender Security included in Section V- Standard forms or any other form acceptable to the Employer. Tender Security shall be valid for **30 days** beyond the validity of the tender.
- 3.9 Any tender not accompanied by an acceptable Tender Security shall be rejected. The Tender Security of a joint venture must define as "Tenderer" all joint venture partners and list them in the following manner: a joint venture consisting of".....", ".....", and ".....".
- 3.10 The Tender Securities of unsuccessful tenderers will be returned within 28 days of the end of the tender validity period specified in Clause 3.6.
- 3.11 The Tender Security of the successful tenderer will be discharged when the tenderer has signed the Contract Agreement and furnished the required Performance Security.
- 3.12 The Tender Security may be forfeited
- (a) if the tenderer withdraws the tender after tender opening during the period of tender validity;
  - (b) if the tenderer does not accept the correction of the tender price, pursuant to Clause 5.7;
  - (c) in the case of a successful tenderer, if the tenderer fails within the specified time limit to
    - (j) sign the Agreement, or
- (ii) Furnish the required Performance Security.

- 3.13 Tenderers shall submit offers that comply with the requirements of the tendering documents, including the basic technical design as indicated in the Drawings and Specifications. Alternatives will not be considered, unless specifically allowed in the invitation to tender. If so allowed, tenderers wishing to offer technical alternatives to the requirements of the tendering documents must also submit a tender that complies with the requirements of the tendering documents, including the basic technical design as indicated in the Drawings and Specifications. In addition to submitting the basic tender, the tenderer shall provide all information necessary for a complete evaluation of the alternative, including design calculations, technical specifications, breakdown of prices, proposed construction methods and other relevant details. Only the technical alternatives, if any, of the lowest evaluated tender conforming to the basic technical requirements shall be considered.
- 3.14 The tenderer shall prepare one original of the documents comprising the tender documents as described in Clause 3.2 of these Instructions to Tenderers, bound with the volume containing the Form of Tender,
- 3.15 And clearly marked "ORIGINAL". In addition, the tenderer shall submit Nil. Copies of the tender, in the number specified in the.
- 3.16 The original and all copies of the tender shall be typed or written in indelible ink and shall be signed by a person or persons duly authorised to sign on behalf of the tenderer, as the case may be. All pages of the tender where alterations or additions have been made shall be initialled by the person or persons signing the tender.
- 3.17 Clarification of tenders shall requested by the tenderers to be received by the procuring entity not later than 7 days prior to the deadline for submission of tenders.
- 3.18 The procuring entity shall reply to any clarifications sought by the tenderer within 3 days of receiving the request to enable the tenderer to make timely submission of its tender.

#### **4. Submission of Tenders**

- 4.1 The tenderer shall seal the original and all copies of the tender in two inner envelopes and one outer envelope, duly marking the inner envelopes as "**ORIGINAL**" and "**COPIES**" as appropriate. The inner and outer envelopes shall:
- (a) be addressed to the Employer at the address provided in the invitation to tender;

- (b) bear the name and identification number of the Contract as defined in the invitation to tender; and
  - (c) Provide a warning not to open before the specified time and date for tender opening.
- 4.2 Tenders shall be delivered to the Employer at the address specified above not later than the time and date specified in the invitation to tender. However, the Employer may extend the deadline for submission of tenders by issuing an amendment in accordance with Sub-Clause 2.5 in which case all rights and obligations of the Employer and the tenderers previously subject to the original deadline will then be subject to the new deadline.
- 4.3 Any tender received after the deadline prescribed in clause 4.2 will be returned to the tenderer un-opened.
- 4.4 Tenderers may modify or withdraw their tenders by giving notice in writing before the deadline prescribed in clause 4.2. Each tenderer's modification or withdrawal notice shall be prepared, sealed, marked, and delivered in accordance with clause 3.13 and 4.1, with the outer and inner envelopes additionally marked "**MODIFICATION**" and "**WITHDRAWAL**", as appropriate. No tender may be modified after the deadline for submission of tenders.
- 4.5 Withdrawal of a tender between the deadline for submission of Tenders and the expiration of the period of tender validity specified in the invitation to tender or as extended pursuant to Clause 3.6 may result in the forfeiture of the Tender Security pursuant to Clause 3.11.
- 4.6 Tenderers may only offer discounts to, or otherwise modify the prices of their tenders by submitting tender modifications in accordance with Clause 4.4 or be included in the original tender submission

## **5. Tender Opening and Evaluation**

- 5.1 The tenderers' names, the tender prices, the total amount of each tender and of any alternative tender (if alternatives have been requested or permitted), any discounts, tender modifications and withdrawals, the presence or absence of Tender Security, and such other details as may be considered appropriate, will be announced by the Employer at the opening. Minutes of the tender opening, including the information disclosed to those present will be prepared by the Employer.
- 5.2 Information relating to the examination, clarification, evaluation, and comparison of tenders and recommendations for the award of

Contract shall not be disclosed to tenderers or any other persons not officially concerned with such process. Any effort by a tenderer to influence the Employer's officials, processing of tenders or award decisions may result in the rejection of his tender.

- 5.3 To assist in the examination, evaluation, and comparison of tenders, the Employer at his discretion, may ask any tenderer for clarification of the tender, including breakdowns of unit rates. The request for clarification and the response shall be in writing or by cable, telex or facsimile but no change in the price or substance of the tender shall be sought, offered, or permitted except as required to confirm the correction of arithmetic errors discovered in the evaluation of the tenders in accordance with Clause 5.7.
- 5.4 Prior to the detailed evaluation of tenders, the Employer will determine whether each tender (a) meets the eligibility criteria defined in Clause 1.7;(b) has been properly signed; (c) is accompanied by the required securities; and (d) itemized bills of quantities is fully priced (e) is substantially responsive to the requirements of the tendering documents. A substantially responsive tender is one which conforms to all the terms, conditions and specifications of the tendering documents, without material deviation or reservation. A material deviation or reservation is one (a) which affects in any substantial way the scope, quality, or performance of the works; (b) which limits in any substantial way, inconsistent with the tendering documents, the Employer's rights or the tenderer's obligations under the Contract; or (c) whose rectification would affect unfairly the competitive position of other tenderers presenting substantially responsive tenders.
- 5.5 If a tender is not substantially responsive, it will be rejected, and may not subsequently be made responsive by correction or withdrawal of the nonconforming deviation or reservation.
- 5.6 Tenders determined to be substantially responsive will be checked for any arithmetic errors. Errors will be corrected as follows:
  - (a) where there is a discrepancy between the amount in figures and the amount in words, the amount in words will prevail; and
  - (b) Where there is a discrepancy between the unit rate and the line item total resulting from multiplying the unit rate by the quantity, the unit rate as quoted will prevail, unless in the opinion of the Employer, there is an obvious typographical error, in which case the adjustment will be made to the entry containing that error.
  - (c) In the event of a discrepancy between the tender amount as stated in the Form of Tender and the corrected tender figure in

the main summary of the Bill of Quantities, the amount as stated in the Form of Tender shall prevail.

- (d) The Error Correction Factor shall be computed by expressing the difference between the tender amount and the corrected tender sum as a percentage of the corrected Builder's Work (i.e. Corrected tender sum less P.C. and Provisional Sums)
- (e) The Error Correction Factor shall be applied to all Builder's Work (as a rebate or addition as the case may be) for the purposes of valuations for Interim Certificates and valuation of variations.
- (f) The amount stated in the tender will be adjusted in accordance with the above procedure for the correction of errors and, with concurrence of the tenderer, shall be considered as binding upon the tenderer. If the tenderer does not accept the corrected amount, the tender may be rejected and the Tender Security may be forfeited in accordance with clause 3.11.
- (g) in the event the magnitude of arithmetical error discovered as here-before described exceeds 2.5% of amount stated in the form of tender the bid shall be declared non responsive and ineligible for award.

5.7 The Employer will evaluate and compare only the tenders determined to be substantially responsive in accordance with Clause 5.5 & 5.6 evaluation shall be in accordance with criteria set out in the appendix to instruction to bidders

5.8 In evaluating the tenders, the Employer will determine for each tender the evaluated tender price by adjusting the tender price as follows:

- (a) making any correction for errors pursuant to clause 5.7;
- (b) Excluding provisional sums and the provision, if any, for contingencies in the Bill of Quantities, but including Day works where priced competitively.
- (c) making an appropriate adjustment for any other acceptable variations, deviations, or alternative offers submitted in accordance with clause 3.12; and
- (d) making appropriate adjustments to reflect discounts or other price modifications offered in accordance with clause 4.6

5.9 The Employer reserves the right to accept or reject any variation, deviation, or alternative offer. Variations, deviations, and alternative offers and other factors which are in excess of the requirements of

the tender documents or otherwise result in unsolicited benefits for the Employer will not be taken into account in tender evaluation.

- 5.10 The tenderer shall not influence the Employer on any matter relating to his tender from the time of the tender opening to the time the Contract is awarded. Any effort by the Tenderer to influence the Employer or his employees in his decision on tender evaluation, tender comparison or Contract award may result in the rejection of the tender.
- 5.11 Firms incorporated in Kenya where indigenous Kenyans own 51% or more of the share capital shall be allowed a 10% preferential bias provided that they do not sub-contract work valued at more than 50% of the Contract Price excluding Provisional Sums to a Non-indigenous sub-contractor.

## **6. Award of Contract**

- 6.1 Subject to Clause 6.2, the award of the Contract will be made to the tenderer whose tender has been determined to be substantially responsive to the tendering requirements as set out in tender documents and in appendix to instruction to bidders and who has offered the lowest evaluated tender price.
- 6.2 Notwithstanding clause 6.1 above, the Employer reserves the right to accept or reject any tender, and to cancel the tendering process and reject all tenders, at any time prior to the award of Contract, without thereby incurring any liability to the affected tenderer or tenderers or any obligation to inform the affected tenderer or tenderers of the grounds for the action.
- 6.3 The tenderer whose tender has been accepted will be notified of the award prior to expiration of the tender validity period in writing or by cable, telex or facsimile. This notification (hereinafter and in all Contract documents called the "Letter of Acceptance") will state the sum (hereinafter and in all Contract documents called the "Contract Price") that the Employer will pay the Contractor in consideration of the execution, completion, and maintenance of the Works by the Contractor as prescribed by the Contract. At the same time the other tenderers shall be informed that their tenders have not been successful.

The contract shall be formed on the parties signing the contract.

- 6.4 The Agreement will incorporate all agreements between the Employer and the successful tenderer. Within 14 days of receipt the successful tenderer will sign the Agreement and return it to the Employer.

- 6.5 Within 28 days after receipt of the Letter of Notification/Acceptance, the successful tenderer shall deliver to the Employer a Performance Security in the amount stipulated in the Appendix to Conditions of Contract and in the form stipulated in the Tender documents. The Performance Security shall be in the amount and specified form
- 6.6 Failure of the successful tenderer to comply with the requirements of clause 6.5 shall constitute sufficient grounds for cancellation of the award and forfeiture of the Tender Security.
- 6.7 Upon the furnishing by the successful tenderer of the Performance Security, the Employer will promptly notify the other tenderers that their tenders have been unsuccessful.
- 6.8 Preference where allowed in the evaluation of tenders shall not be allowed for contracts not exceeding one year (12 months)
- 6.9 The parties to the contract shall have it signed within 30 days from the date of notification of contract award unless there is an administrative review request.
- 6.10 Contract price variations shall not be allowed for contracts not exceeding one year (12 months)
- 6.11 Where contract price variation is allowed, the valuation shall not exceed 25% of the original contract price.
- 6.12 Price variation request shall be processed by the procuring entity within 30 days of receiving the request.
- 6.13 The procuring entity may at any time terminate procurement proceedings before contract award and shall not be liable to any person for the termination.
- 6.14 A tenderer who gives false information in the tender document about its qualification or who refuses to enter into a contract after notification of contract award shall be considered for debarment from participating in future public procurement.

## **7. Corrupt and Fraudulent practices**

- 7.1 The procuring entity requires that tenderers observe the highest standards of ethics during procurement process and execution of contracts. A tenderer shall sign a declaration that he has not and will not be involved in corrupt and fraudulent practices.

## **8. Description of Works.**



8.1 The project is located within the Meru N. Park.

8.2 The works under this Contract is **LABOUR ONLY** and shall comprise but are not limited to the following:

**A. CONSTRUCTION**

- 1) Clearing of site 3m on either side along the alignment
- 2) Pegging
- 3) Excavation of holes to receive treated posts
- 4) Construction of assemblies: single, double and corners
- 4) Backfilling and ramming of posts
- 5) Tying of strainers, porcelain insulators and reel fasteners
- 6) Fixing of W - Insulators
- 7) Straining of wires: HTS, soft wires
- 8) Fabrication and fixing of steel gates
- 9) Construction of Uni- huts
- 10) Installation of solar panel and Energizers
- 11) Powering
- 12) Testing & Commissioning

**B. MAINTENANCE (FOR 2 YEAR PERIOD)**

- 18) Maintenance - Performance Based Maintenance Contract (PBC)

## SECTION III

### APPENDIX TO INSTRUCTION TO TENDERERS

Particulars of appendix to instruction to tenderers

#### (a) Submission of bids

The tender submitted should comprise the following documents **PRESENTED IN THE ORDER GIVEN BELOW**- Marks to be awarded for presentation. Further the document must be sequentially paginated and book or tape bound.

- A. Tender Security as stipulated in advert or invitation to bid in strict adherence to format provided herewith
- B. Duly filled and signed form of tender,
- C. Serially paginated document
- D. A signed declaration that the bidder will not engage in any corrupt or fraudulent practice.
- E. **Certified copy** of Certificate of incorporation/business Registration Certificate
- F. **Certified**(commission of oath) copy of current CR12, not older than six months from date of tender closing
- G. Confidential Business Questionnaire Ref: tender document page 61-62
- H. copy Registration certificate with National Construction Authority as a general buildings or Civil contractor Category **NCA-6 and 5 respectively** or above and specialist contractor (Electrical) category **NCA 5** or above and licence from communication authority of Kenya (**CA**).
- I. **Certified** current Power of attorney to sign tender documents, not older than six months from date of tender closing .
- J. Valid Tax Compliance Certificate
- K. **Certified** valid Single Business Permit from respective county government
- L. authority to seek references from the tenderer's Bankers
- M. Attorney authenticated Litigation history For the past three years 2018,2019,2020
- N. Audited accounts for the last Two years or **CERTIFIED** copies of bank statements covering a period of at least 24 months prior to the date of the tender closing. The copies should be certified by the Bank issuing the statements. Annual volume of construction work of Kshs. 15 million per year borne from turnover in audited accounts for the past two years, or cumulative volume of transactions evidenced in bank statement
- O. Program of works showing clearly the sequencing of project activities within pre determined contract period within which the works shall be

carried out to completion and cash-flow projection showing clearly expected monthly cash disbursement over the contract duration based on tender sum quoted.

P. Key staff competency profiles (project manager & Site agent, Foreman)

Qualifications and experience of key site management and technical personnel proposed for the contract supported by academic and professional certificates in addition to signed curriculum vitae, Project manager, site agent and foreman

- An project manager with a minimum of 5 years specific experience in building/Civil/Electrical construction supervision or works of an equivalent nature and volume, with a minimum of degree in – Building/Civil engineering/Electrical Engineering, field or equivalent from a recognised Institution
- A Site Agent with a minimum of 3 years specific experience in building/civil/electrical construction works or works of an equivalent nature and volume, with a minimum of Higher National Diploma in buildings related course or equivalent from a recognized institution.
- A foreman with a minimum of 3 years specific experience in building (construction works or works of an equivalent nature and volume, with a minimum of An Ordinary Diploma in building/civil/electrical related course or equivalent from a recognized institution

Q. Details of experience as main contractor in the construction of Wildlife electrical fences of at least two works of a nature and complexity equivalent to the Works (kshs 15 million) over the last 5 years (to comply with this requirement, works cited should be at least 70 percent complete); supported by copies of award letter, or extract form of Signed Agreement and At least recommendation letters per job from Qualified and registered engineer or architect who was been directly involved in supervision of the works. Recommendation by professional to be accompanied by copy of respective professional registration certificate or practicing license. The recommendation letter should highlight among other things the

- i. name of the project,
- ii. contract value,
- iii. Client name, client physical addresses, client email/telephone number.
- iv. Status of completeness of the work or otherwise.

*NB: Professional recommendations not accompanied referees certificates/license and vice versa shall be disregarded for purposes of evaluation*

R. Evidence of Liquid assets and or credit facilities, net of other contractual commitments and exclusive of any advance payments which may be made under the Contract, of no less than 3 months of the estimated payment flow under this Contract. i.e. to mean Evidence of liquid assets or credit

facilities, either from the bank credit facilities , credit facilities from major relevant materials suppliers, manufacturers or dealers all adding up to a minimum Cumulative facility of Kshs 2.7 million

- S. Adequate equipment for the specified type of Work giving details and evidence as to whether owned or leased, Proposals for the timely acquisition (own, lease, hire, etc.) of the essential equipment as required for the Works – if owned then copies of logbooks Must be attached, for lease or hire, to be supported by lease/hire agreement

## **b) Tender Evaluation Criteria.**

The following criteria shall be used in evaluation of all bids.

### **1.1 Mandatory Requirements** (failure to fully comply shall lead to disqualification)

- A. Tender Security as stipulated in advert or invitation to bid in strict adherence to format provided herewith
- B. Duly filled and signed form of tender
- C. Dully filled itemized bills of quantities
- D. Serially paginated document
- E.** A signed declaration that the bidder will not engage in any corrupt or fraudulent practice.
- F. **Certified (commission of oath)** copy of Certificate of incorporation/business Registration Certificate
- G. **Certified (commission of oath)** copy of current CR12, not older than six months from date of tender closing
- H. Confidential Business Questionnaire Ref: tender document page 61-62
- I. Copy Registration certificate with National Construction Authority as a general buildings or Civil contractor Category **NCA-6 and 5 respectively** or above, and specialist contractor (electrical) category **NCA -6** or above and licence from communication authority of Kenya (**CA**).Current Annual NCA Contractors practicing licence.
- J. **Certified (commission of oath)** current Power of attorney to sign tender documents, not older than six months from date of tender closing .
- K. Valid Tax Compliance Certificate
- L. **Certified** (commission of oath)valid Single Business Permit from respective county government
- M. Tender specific authority to seek references from the tenderer's Bankers
- N. Attorney authenticated Litigation history For the past three years 2018,2019,2020
- O. Audited accounts for the past two calendar years preceding closure of tender or **CERTIFIED** copies of bank statements covering a period of at least 24 months prior to the date of the tender closing.

## 1.2 Technical evaluation requirements

Any tenderer who fails to submit or meet the mandatory requirements will be disqualified and will not be eligible to proceed to technical evaluation stage

Score sheet				Marks		
1	<b>TECHNICAL Document presentation</b>  <b>Total Marks 5</b>	Presentation and response (this includes binding the document and neat and orderly presentation, separation and arrangement of requested information & general response to all requirements	Compliance	<b>5</b>		
2	<b>EQUIPMENT</b>  <b>Total Marks 20</b>	Ownership list of required equipment and/or Current authorization letter of hiring from M&T or reputable hiring company	<b>No required</b>	<b>4</b>		
			7 ton truck		<b>1</b>	
			I ton pick - up truck	<b>1</b>	<b>4</b>	
			Tractor & Trailer	<b>1</b>	<b>4</b>	
			Single Strainer	<b>2</b>	<b>2</b>	
			Maun cutting plier	<b>4</b>	<b>2</b>	
			Wire dispenser	<b>2</b>	<b>2</b>	
3	<b>KEY PERSONNEL</b>  <b>Total Marks 17</b>	Provide List Key Site technical staff, their <ul style="list-style-type: none"> <li>CVs and resume. –</li> <li>General Experience (CV),</li> <li>-Certified Qualification Certificate,</li> </ul>	Dvm	<b>3</b>	<b>2</b>	
			Project manager	<b>Degree</b> in Civil Eng/architecture/quantity surveying/Electrical	<b>3</b>	
				Exp. 5 Yrs and above		<b>2</b>
				Signed CV		<b>2</b>
			Site Agent	<b>Higher national dip</b> in building/civil/electrical related course	<b>3</b>	
				Exp. 3 Yrs and above		<b>2</b>
Signed CV	<b>2</b>					
Foreman	<b>ordinary dip</b> in building/civil/electrical related course	<b>1</b>				
	Exp. 3 Yrs and above		<b>1</b>			
	Signed CV		<b>1</b>			
4	<b>PAST RELEVANT WORK EXPERIENCE</b>  <b>Total marks 30 marks</b>	Details of experience as main contractor in the construction of at least two works of a nature and complexity equivalent to the Works (kshs 15 million) over the last 5 years (to comply with this requirement, works cited should be at least 70 percent complete);	Job (1) Kshs 10m or above- copy award letter or signed agreement	<b>8</b>		
			Recommendation letter from professional referee in respect to job (1) above	<b>4</b>		
			Referees registration certificate or practicing license Job (1) above	<b>3</b>		
			Job (2) Kshs 10m or above- copy award letter or signed agreement	<b>8</b>		
			Recommendation letter from professional referee in respect to job (2) above	<b>4</b>		
			Referees registration certificate or practicing license Job (2) above	<b>3</b>		
5	<b>LITIGATION</b>		2018			

	<b>HISTORY</b> <b>Total marks 6</b>	Record of litigation in the previous 3 years. Attach Authenticated litigation history			<b>2</b>
				2019	<b>2</b>
				2020	<b>2</b>
<b>6</b>	<b>FINANCIAL CAPABILITY</b>  <b>Total marks 16</b>	Certified audited accounts for the last Two (2) yrs , or bank statements last 24 months	Average construction turnover. 20 Million per financial year	2019	<b>7</b>
				2020	<b>7</b>
		Evidence of liquid assets or credit facilities, either from the bank credit facilities , credit facilities from major relevant materials suppliers, manufacturers or dealers all adding up to a minimum Cumulative facility of kshs 3.0 million		Kshs 3.0million	<b>2</b>
<b>7</b>	<b>WORK EXECUTION PROGRAMME</b>  <b>Total Marks 6</b>	Working Schedule and Projected Cash flow		Work Programme	<b>4</b>
				Cash flow plan	<b>2</b>
<b>TOTAL SCORE</b>					<b>100</b>

A cut off point of **70** score shall apply meaning that any firm that scores below 70 points on the 100 points scale in technical evaluation, shall be deemed to be non responsive and thus not eligible for financial evaluation.

### **1.3 Financial Evaluation**

Financial evaluation of bids that meet minimum technical criteria will be done. To ascertain compliance to requirements set out in the tender document.

To qualify for award the bidder must satisfy the following financial eligibility criteria

- (a) The bidder must concur to verification of bid correctness in line with instruction to bidders clause 5.7
- (b) in the event the magnitude of arithmetical error discovered exceeds 2.5% of amount stated in the form of tender the bid shall declared non responsive and ineligible for award.
- (c) Prices quoted must be valid for 90 days

### **1.4 Award**

The award of the Contract will be made to the lowest evaluated tenderer whose tender has been determined to be substantially responsive and in full compliance to the mandatory, technical and financial evaluation requirements.

### **NB: Post Qualification & Due Diligence**

Prior to recommendation for award the employer reserves the right to make physical visit to successful bidders premises or works undertaken or both to undertake due diligence. Should there emanate evidence of material discrepancy

or inconsistencies between the information submitted by the bidder and actual circumstances on the ground as witnessed during due diligence, then this shall form a sufficient ground for rejection of the bid in spite of having fulfilled all other relevant evaluation criteria requirements, in which event the Procuring Entity will proceed to the next lowest evaluated Tender to make a similar determination of that Tenderer's capabilities to perform satisfactorily.

## **SECTION IV                      CONDITIONS OF CONTRACT**

### *Table of Contents*

1	Definitions .....	24
2	Interpretation.....	26
3	Language and Law .....	27
4	Project Manager's Decisions.....	27
5	Delegation.....	27
6	Communications .....	27
7	Sub Contracting .....	27
8	Other Contractors .....	27
9	Personnel .....	27
10	Works.....	28
11	Safety and temporary works .....	28
12	Discoveries .....	28
13	Work Programme .....	28
14	Possession of site .....	28
15	Access to site .....	29
16	Instructions .....	29
17	Extension or Acceleration of completion date .....	29
18	Management Meetings .....	30
19	Early Warning .....	30
20	Defects .....	30
21	Bills of Quantities .....	31
22	Variations .....	31
23	Payment certificates, currency of payments and Advance Payments .....	32
24	Compensation events .....	34
25	Price Adjustment .....	36
26	Retention .....	37

27	Liquidated Damages.....	37
28	Securities .....	38
29	Day Works .....	38
30	Liability and Insurance .....	38
31	Completion and taking over .....	40
32	Final Account .....	40
33	Termination .....	40
34	Payment upon termination .....	41
35	Release from performance .....	42
36	Corrupt gifts and payments of commission .....	42
37	Settlement of Disputes .....	43

## **CONDITIONS OF CONTRACT**

### **1. Definitions**

1.1 In this Contract, except where context otherwise requires, the following terms shall be interpreted as indicated;

**“Bill of Quantities”** means the priced and completed Bill of Quantities forming part of the tender.

**“Compensation Events”** are those defined in Clause 24 hereunder.

**“The Completion Date”** means the date of completion of the Works as certified by the Project Manager, in accordance with Clause 31.

**“The Contract”** means the agreement entered into between the Employer and the Contractor as recorded in the Agreement Form and signed by the parties including all attachments and appendices thereto and all documents incorporated by reference therein to execute, complete, and maintain the Works,

**“The Contractor”** refers to the person or corporate body whose tender to carry out the Works has been accepted by the Employer.

**“The Contractor’s Tender”** is the completed tendering document submitted by the Contractor to the Employer.

**“The Contract Price”** is the price stated in the Letter of Acceptance and thereafter as adjusted in accordance with the provisions of the Contract.



**“Days”** are calendar days; **“Months”** are calendar months.

**“A Defect”** is any part of the Works not completed in accordance with the Contract.

**“The Defects Liability Certificate”** is the certificate issued by Project Manager upon correction of defects by the Contractor.

**“The Defects Liability Period”** is the period named in the Contract Data and calculated from the Completion Date.

**“Drawings”** include calculations and other information provided or approved by the Project Manager for the execution of the Contract.

**“Dayworks”** are Work inputs subject to payment on a time basis for labour and the associated materials and plant.

**“Employer”**, or the **“Procuring entity”** as defined in the Public Procurement Regulations (i.e. Central or Local Government administration, Universities, Public Institutions and Corporations, etc) is the party who employs the Contractor to carry out the Works.

**“Equipment”** is the Contractor’s machinery and vehicles brought temporarily to the Site for the execution of the Works.

**“The Intended Completion Date”** is the date on which it is intended that the Contractor shall complete the Works. The Intended Completion Date may be revised only by the Project Manager by issuing an extension of time or an acceleration order.

**“Materials”** are all supplies, including consumables, used by the Contractor for incorporation in the Works.

**“Plant”** is any integral part of the Works that shall have a mechanical, electrical, chemical, or biological function.

**“Project Manager”** is the person named in the Appendix to Conditions of Contract (or any other competent person appointed by the Employer and notified to the Contractor, to act in replacement of the Project Manager who is responsible for supervising the execution of the Works and administering the Contract and shall be an **“Engineer”** registered under Engineers Registration Act Cap 530.

**“Site”** is the area defined as such in the Appendix to Condition of Contract.

**“Site Investigation Reports”** are those reports that may be included in the tendering documents which are factual and interpretative about the surface and subsurface conditions at the Site.

**“Specifications”** means the Specifications of the Works included in the Contract and any modification or addition made or approved by the Project Manager.

**“Start Date”** is the latest date when the Contractor shall commence execution of the Works. It does not necessarily coincide with the Site possession date(s).

**“A Subcontractor”** is a person or corporate body who has a Contract with the Contractor to carry out a part of the Work in the Contract, which includes Work on the Site.

**“Temporary works”** are works designed, constructed, installed, and removed by the Contractor which are needed for construction or installation of the Works.

**“A Variation”** is an instruction given by the Project Manager which varies the Works.

**“The Works”** are what the Contract requires the Contractor to construct, install, and turnover to the Employer, as defined in the Appendix to Conditions of Contract.

## **2. Interpretation**

- 2.1 In interpreting these Conditions of Contract, singular also means plural, male also means female or neuter, and the other way around. Headings have no significance. Words have their normal meaning in English Language unless specifically defined. The Project Manager will provide instructions clarifying queries about these Conditions of Contract.
- 2.2 If sectional completion is specified in the Appendix to Conditions of Contract, reference in the Conditions of Contract to the Works, the Completion Date and the Intended Completion Date apply to any section of the Works (other than references to the Intended Completion Date for the whole of the Works).
- 2.3 The following documents shall constitute the Contract documents and shall be interpreted in the following order of priority;
  - (1) Agreement,
  - (2) Letter of Acceptance,
  - (3) Contractor’s Tender,
  - (4) Appendix to Conditions of Contract,
  - (5) Conditions of Contract,

- (6) Specifications,
- (7) Drawings,
- (8) Bill of Quantities,
- (9) Performance based maintenances
- (10) Any other documents listed in the Appendix to Conditions of Contract as forming part of the Contract.

Immediately after the execution of the Contract, the Project Manager shall furnish both the Employer and the Contractor with two copies each of all the Contract documents. Further, as and when necessary the Project Manager shall furnish the Contractor always with a copy to the Employer] with three [3] copies of such further drawings or details or descriptive schedules as are reasonably necessary either to explain or amplify the Contract drawings or to enable the Contractor to carry out and complete the Works in accordance with these Conditions.

### **3. Language and Law**

- 3.1** Language of the Contract and the law governing the Contract shall be English language and the Laws of Kenya respectively unless otherwise stated.

### **4 Project Manager's Decisions**

- 4.1** Except where otherwise specifically stated, the Project Manager will decide contractual matters between the Employer and the Contractor in the role representing the Employer.

### **5 Delegation**

- 5.1** The Project Manager may delegate any of his duties and responsibilities to others after a notifying the Contractor in writing.

### **6 Communications**

- 6.1** Communication between parties shall be effective only when in writing. A notice shall be effective only when it is delivered.

### **7 Subcontracting**

- 7.1** The Contractor may subcontract with the approval of the Project Manager, but may not assign the Contract without the approval of the Employer in writing. Subcontracting shall not alter the Contractor's obligations.

## **8 Other Contractors**

8.1 The Contractor shall cooperate and share the Site with other contractors, public authorities, utilities etc. as listed in the Appendix to Conditions of Contract and also with the Employer, as per the directions of the Project Manager. The Contractor shall also provide facilities and services for them. The Employer may modify the said List of Other Contractors etc., and shall notify the Contractor of any such modification.

## **9 Personnel**

9.1 The Contractor shall employ the key personnel named in the Qualification Information, to carry out the functions stated in the said Information or other personnel approved by the Project Manager. The Project Manager will approve any proposed replacement of key personnel only if their relevant qualifications and abilities are substantially equal to or better than those of the personnel listed in the Qualification Information. If the Project Manager asks the Contractor to remove a person who is a member of the Contractor's staff or work force, stating the reasons, the Contractor shall ensure that the person leaves the Site within seven days and has no further connection with the Work in the Contract.

Contractor will source unskilled labour from the local communities surrounding the project upon verification by the local administration and the Employer.

## **10 Works**

10.1 The Contractor shall construct and install the Works in accordance with the Specifications and Drawings. The Works may commence on the Start Date and shall be carried out in accordance with the Program submitted by the Contractor, as updated with the approval of the Project Manager, and complete them by the Intended Completion Date.

## **11 Safety and Temporary Works**

11.1 The Contractor shall be responsible for the design of temporary works. However before erecting the same, he shall submit his designs including specifications and drawings to the Project Manager and to any other relevant third parties for their approval. No erection of temporary works shall be done until such approvals are obtained.

11.2 The Project Manager's approval shall not alter the Contractor's responsibility for design of the Temporary works and all drawings prepared by the Contractor for the execution of the temporary or permanent Works, shall be subject to prior approval by the Project Manager before they can be used.

**11.3** The Contractor shall be responsible for the safety of all activities on the Site.

## **12. Discoveries**

12.1 Anything of historical or other interest or of significant value unexpectedly discovered on Site shall be the property of the Employer. The Contractor shall notify the Project Manager of such discoveries and carry out the Project Manager's instructions for dealing with them.

## **13. Work Program**

**13.1** Within the time stated in the Appendix to Conditions of Contract, the Contractor shall submit to the Project Manager for approval a program showing the general methods, arrangements, order, and timing for all the activities in the Works. An update of the program shall be a program showing the actual progress achieved on each activity and the effect of the progress achieved on the timing of the remaining Work, including any changes to the sequence of the activities.

The Contractor shall submit to the Project Manager for approval an updated program at intervals no longer than the period stated in the Appendix to Conditions of Contract. If the Contractor does not submit an updated program within this period, the Project Manager may withhold the amount stated in the said Appendix from the next payment certificate and continue to withhold this amount until the next payment after the date on which the overdue program has been submitted. The Project Manager's approval of the program shall not alter the Contractor's obligations. The Contractor may revise the program and submit it to the Project Manager again at any time. A revised program shall show the effect of Variations and Compensation Events.

## **14. Possession of Site**

**14.1** The Employer shall give possession of all parts of the Site to the Contractor. If possession of a part is not given by the date stated in the Appendix to Conditions of Contract, the Employer will be deemed to have delayed the start of the relevant activities, and this will be a Compensation Event.

## **15. Access to Site**

**15.1** The Contractor shall allow the Project Manager and any other person authorized by the Project Manager, access to the Site and to any place where work in connection with the Contract is being carried out or is intended to be carried out.

## **16. Instructions**

**16.1** The Contractor shall carry out all instructions of the Project Manager which are in accordance with the Contract.

## **17. Extension or Acceleration of Completion Date**

**17.1** The Project Manager shall extend the Intended Completion Date if a Compensation Event occurs or a variation is issued which makes it impossible for completion to be achieved by the Intended Completion Date without the Contractor taking steps to accelerate the remaining Work, which would cause the Contractor to incur additional cost. The Project Manager shall decide whether and by how much to extend the Intended Completion Date within 21 days of the Contractor asking the Project Manager in writing for a decision upon the effect of a Compensation Event or variation and submitting full supporting information. If the Contractor has failed to give early warning of a delay or has failed to cooperate in dealing with a delay, the delay caused by such failure shall not be considered in assessing the new (extended) Completion Date.

**17.2** No bonus for early completion of the Works shall be paid to the Contractor by the Employer.

## **18. Management Meetings**

**18.1** A Contract management meeting shall be held monthly and attended by the Project Manager and the Contractor. Its business shall be to review the plans for the remaining Work and to deal with matters raised in accordance with the early warning procedure. The Project Manager shall record the minutes of management meetings and provide copies of the same to those attending the meeting and the Employer. The responsibility of the parties for actions to be taken shall be decided by the Project Manager either at the management meeting or after the management meeting and stated in writing to all who attended the meeting.

## **19. Early Warning**

**19.1** The Contractor shall warn the Project Manager at the earliest opportunity of specific likely future events or circumstances that may adversely affect the quality of the Work, increase the Contract Price or delay the execution of the Works. The Project Manager may require the Contractor to provide an estimate of the expected effect of the future event or circumstance on the Contract Price and Completion Date. The estimate shall be provided by the Contractor as soon as reasonably possible.

**19.2** The Contractor shall cooperate with the Project Manager in making and considering proposals on how the effect of such an event or

circumstance can be avoided or reduced by anyone involved in the Work and in carrying out any resulting instructions of the Project Manager.

## **20. Defects**

- 20.1** The Project Manager shall inspect the Contractor's work and notify the Contractor of any defects that are found. Such inspection shall not affect the Contractor's responsibilities. The Project Manager may instruct the Contractor to search for a defect and to uncover and test any Work that the Project Manager considers may have a defect. Should the defect be found, the cost of uncovering and making good shall be borne by the Contractor. However, if there is no defect found, the cost of uncovering and making good shall be treated as a variation and added to the Contract Price.
- 20.2** The Project Manager shall give notice to the Contractor of any defects before the end of the Defects Liability Period, which begins at Completion, and is defined in the Appendix to Conditions of Contract. The Defects Liability Period shall be extended for as long as defects remain to be corrected.
- 20.3** Every time notice of a defect is given, the Contractor shall correct the notified defect within the length of time specified by the Project Manager's notice. If the Contractor has not corrected a defect within the time specified in the Project Manager's notice, the Project Manager will assess the cost of having the defect corrected by other parties and such cost shall be treated as a variation and be deducted from the Contract Price.

## **21. Bills Of Quantities**

- 21.1** The Bills of Quantities shall contain items for the construction, installation, testing and commissioning of the Work to be done by the Contractor. The Contractor will be paid for the quantity of the Work done at the rate in the Bills of Quantities for each item.
- 21.2** If the final quantity of the Work done differs from the quantity in the Bills of Quantities for the particular item by more than 25 percent and provided the change exceeds 1 percent of the Initial Contract price, the Project Manager shall adjust the rate to allow for the change.
- 21.3** If requested by the Project Manager, the Contractor shall provide the Project Manager with a detailed cost breakdown of any rate in the Bills of Quantities.

## **22. Variations**

- 22.1** All variations shall be included in updated programs produced by the Contractor.
- 22.2** The Contractor shall provide the Project Manager with a quotation for carrying out the variations when requested to do so. The Project Manager shall assess the quotation, which shall be given within seven days of the request or within any longer period as may be stated by the Project Manager and before the Variation is ordered.
- 22.3** If the work in the variation corresponds with an item description in the Bills of Quantities and if in the opinion of the Project Manager, the quantity of work is not above the limit stated in Clause 21.2 or the timing of its execution does not cause the cost per unit of quantity to change, the rate in the Bills of Quantities shall be used to calculate the value of the variation. If the cost per unit of quantity changes, or if the nature or timing of the work in the variation does not correspond with items in the Bills of Quantities, the quotation by the Contractor shall be in the form of new rates for the relevant items of Work.
- 22.4** If the Contractor's quotation is unreasonable, the Project Manager may order the variation and make a change to the Contract price, which shall be based on the Project Manager's own forecast of the effects of the variation on the Contractor's costs.
- 22.5** If the Project Manager decides that the urgency of varying the Work would prevent a quotation being given and considered without delaying the Work, no quotation shall be given and the variation shall be treated as a Compensation Event.
- 22.6** The Contractor shall not be entitled to additional payment for costs that could have been avoided by giving early warning.
- 22.7** When the Program is updated, the Contractor shall provide the Project Manager with an updated cash flow forecast.

### **23. Payment Certificates, Currency of Payments and Advance Payments**

- 23.1** The Contractor shall submit to the Project Manager monthly applications for payment giving sufficient details of the Work done and materials on Site and the amounts which the Contractor considers himself to be entitled to. The Project Manager shall check the monthly application and certify the amount to be paid to the Contractor within 14 days. The value of Work executed and payable shall be determined by the Project Manager.



- 23.2** The value of Work executed shall comprise the value of the quantities of the items in the Bills of Quantities completed; materials delivered on Site, variations and compensation events. Such materials shall become the property of the Employer once the Employer has paid the Contractor for their value. Thereafter, they shall not be removed from Site without the Project Manager's instructions except for use upon the Works.
- 23.3** Payments shall be adjusted for deductions for retention. The Employer shall pay the Contractor the amounts certified by the Project Manager within 30 days of the date of issue of each certificate. If the Employer makes a late payment, the Contractor shall be paid simple interest on the late payment in the next payment. Interest shall be calculated on the basis of number of days delayed at a rate three percentage points above the Central Bank of Kenya's average rate for base lending prevailing as of the first day the payment becomes overdue.
- 23.4** If an amount certified is increased in a later certificate or as a result of an award by an Arbitrator, the Contractor shall be paid interest upon the delayed payment as set out in this clause. Interest shall be calculated from the date upon which the increased amount would have been certified in the absence of dispute.
- 23.5** Items of the Works for which no rate or price has been entered in will not be paid for by the Employer and shall be deemed covered by other rates and prices in the Contract.
- 23.6** The Contract Price shall be stated in Kenya Shillings. All payments to the Contractor shall be made in Kenya Shillings and foreign currency in the proportion indicated in the tender, or agreed prior to the execution of the Contract Agreement and indicated therein. The rate of exchange for the calculation of the amount of foreign currency payment shall be the rate of exchange indicated in the Appendix to Conditions of Contract. If the Contractor indicated foreign currencies for payment other than the currencies of the countries of origin of related goods and services the Employer reserves the right to pay the equivalent at the time of payment in the currencies of the countries of such goods and services. The Employer and the Project Manager shall be notified promptly by the Contractor of any changes in the expected foreign currency requirements of the Contractor during the execution of the Works as indicated in the Schedule of Foreign Currency Requirements and the foreign and local currency portions of the balance of the Contract Price shall then be amended by agreement between Employer and the Contractor in order to reflect appropriately such changes.

23.7 In the event that an advance payment is granted, the following shall apply:-

- a) On signature of the Contract, the Contractor shall at his request, and without furnishing proof of expenditure, be entitled to an advance not exceeding 20% (twenty percent) of the original amount of the Contract. The advance shall not be subject to retention money.
- b) No advance payment may be made before the Contractor has submitted proof of the establishment of deposit or a directly liable guarantee satisfactory to the Employer in the amount of the advance payment. The guarantee shall be in the same currency as the advance.
- c) Reimbursement of the lump sum advance shall be made by deductions from the Interim payments and where applicable from the balance owing to the Contractor. Reimbursement shall begin when the amount of the sums due under the Contract reaches 20% of the original amount of the Contract. It shall have been completed by the time 80% of this amount is reached.

The amount to be repaid by way of successive deductions shall be calculated by means of the formula:

$$R = \frac{A(x^1 - x^{11})}{80 - 20}$$

Where:

R = the amount to be reimbursed

A = the amount of the advance which has been granted

X<sup>1</sup> = the amount of proposed cumulative payments as a percentage of the original amount of the Contract. This figure will exceed 20% but not exceed 80%.

X<sup>11</sup> = the amount of the previous cumulative payments as a percentage of the original amount of the Contract. This figure will be below 80% but not less than 20%.

- d) With each reimbursement the counterpart of the directly liable guarantee may be reduced accordingly.

## **24. Compensation Events**

**24.1** The following issues shall constitute Compensation Events:

- (a) The Employer does not give access to a part of the Site by the Site Possession Date stated in the Appendix to Conditions of Contract.
- (b) The Employer modifies the List of Other Contractors, etc., in a way that affects the Work of the Contractor under the Contract.
- (c) The Project Manager orders a delay or does not issue drawings, specifications or instructions required for execution of the Works on time.
- (d) The Project Manager instructs the Contractor to uncover or to carry out additional tests upon the Work, which is then found to have no defects.
- (e) The Project Manager unreasonably does not approve a subcontract to be let.
- (f) Ground conditions are substantially more adverse than could reasonably have been assumed before issuance of the Letter of Acceptance from the information issued to tenderers (including the Site investigation reports), from information available publicly and from a visual inspection of the Site.
- (g) The Project Manager gives an instruction for dealing with an unforeseen condition, caused by the Employer or additional work required for safety or other reasons.
- (h) Other contractors, public authorities, utilities, or the Employer does not work within the dates and other constraints stated in the Contract, and they cause delay or extra cost to the Contractor.
- (i) The effects on the Contractor of any of the Employer's risks.
- (j) The Project Manager unreasonably delays issuing a Certificate of Completion.
- (k) Other compensation events described in the Contract or determined by the Project Manager shall apply.

**24.2** If a compensation event would cause additional cost or would prevent the Work being completed before the Intended Completion Date, the Contract Price shall be increased and/or the Intended Completion Date shall be extended. The Project Manager shall decide whether and by how much the Contract Price shall be increased and whether and by how much the Intended Completion Date shall be extended.

- 24.3** As soon as information demonstrating the effect of each compensation event upon the Contractor's forecast cost has been provided by the Contractor, it shall be assessed by the Project Manager, and the Contract Price shall be adjusted accordingly. If the Contractor's forecast is deemed unreasonable, the Project Manager shall adjust the Contract Price based on the Project Manager's own forecast. The Project Manager will assume that the Contractor will react competently and promptly to the event.
- 24.4** The Contractor shall not be entitled to compensation to the extent that the Employer's interests are adversely affected by the Contractor not having given early warning or not having co-operated with the Project Manager.
- 24.5** Prices shall be adjusted for fluctuations in the cost of inputs only if provided for in the Appendix to Conditions of Contract.
- 24.6** The Contractor shall give written notice to the Project Manager of his intention to make a claim within thirty days after the event giving rise to the claim has first arisen. The claim shall be submitted within thirty days thereafter.

Provided always that should the event giving rise to the claim of continuing effect, the Contractor shall submit an interim claim within the said thirty days and a final claim within thirty days of the end of the event giving rise to the claim.

## **25. Price Adjustment**

- 25.1** The Project Manager shall adjust the Contract Price if taxes, duties and other levies are changed between the date 30 days before the submission of tenders for the Contract and the date of Completion. The adjustment shall be the change in the amount of tax payable by the Contractor.
- 25.2** The Contract Price shall be deemed to be based on exchange rates current at the date of tender submission in calculating the cost to the Contractor of materials to be specifically imported (by express provisions in the Contract Bills of Quantities or Specifications) for permanent incorporation in the Works. Unless otherwise stated in the Contract, if at any time during the period of the Contract exchange rates shall be varied and this shall affect the cost to the Contractor of such materials, then the Project Manager shall assess the net difference in the cost of such materials. Any amount from time to time so assessed shall be added to or deducted from the Contract Price, as the case may be.
- 25.3** Unless otherwise stated in the Contract, the Contract Price shall be deemed to have been calculated in the manner set out below and in

sub-clauses 25.4 and 25.5 and shall be subject to adjustment in the events specified there under;

- (i) The prices contained in the Contract Bills of Quantities shall be deemed to be based upon the rates of wages and other emoluments and expenses as determined by the Joint Building Council of Kenya (J.B.C.) and set out in the schedule of basic rates issued 30 days before the date for submission of tenders. A copy of the schedule used by the Contractor in his pricing shall be attached in the Appendix to Conditions of Contract.
- (ii) Upon J.B.C. determining that any of the said rates of wages or other emoluments and expenses are increased or decreased, then the Contract Price shall be increased or decreased by the amount assessed by the Project Manager based upon the difference, expressed as a percentage, between the rate set out in the schedule of basic rates issued 30 days before the date for submission of tenders and the rate published by the J.B.C. and applied to the quantum of labor incorporated within the amount of Work remaining to be executed at the date of publication of such increase or decrease.
- (iii) No adjustment shall be made in respect of changes in the rates of wages and other emoluments and expenses which occur after the date of Completion except during such other period as may be granted as an extension of time under clause 17.0 of these Conditions.

**25.4** The prices contained in the Contract Bills of Quantities shall be deemed to be based upon the basic prices of materials to be permanently incorporated in the Works as determined by the J.B.C. and set out in the schedule of basic rates issued 30 days before the date for submission of tenders. A copy of the schedule used by the Contractor in his pricing shall be attached in the Appendix to Conditions of Contract.

**25.5** Upon the J.B.C. determining that any of the said basic prices are increased or decreased then the Contract Price shall be increased or decreased by the amount to be assessed by the Project Manager based upon the difference between the price set out in the schedule of basic rates issued 30 days before the date for submission of tenders and the rate published by the J.B.C. and applied to the quantum of the relevant materials which have not been taken into account in arriving at the amount of any interim certificate under clause 23 of these Conditions issued before the date of publication of such increase or decrease.

**25.6** No adjustment shall be made in respect of changes in basic prices of materials which occur after the date for Completion except during such other period as may be granted as an extension of time under clause 17.0 of these Conditions.

**25.7** The provisions of sub-clause 25.1 to 25.2 herein shall not apply in respect of any materials included in the schedule of basic rates.

## **26. Retention**

**26.1** The Employer shall retain from each payment due to the Contractor the proportion stated in the Appendix to Conditions of Contract until Completion of the whole of the Works. On Completion of the whole of the Works, half the total amount retained shall be repaid to the Contractor and the remaining half when the Defects Liability Period has passed and the Project Manager has certified that all defects notified to the Contractor before the end of this period have been corrected.

## **27. Liquidated Damages**

**27.1** The Contractor shall pay liquidated damages to the Employer at the rate stated in the Appendix to Conditions of Contract for each day that the actual Completion Date is later than the Intended Completion Date. The Employer may deduct liquidated damages from payments due to the Contractor. Payment of liquidated damages shall not alter the Contractor's liabilities.

**27.2** If the Intended Completion Date is extended after liquidated damages have been paid, the Project Manager shall correct any overpayment of liquidated damages by the Contractor by adjusting the next payment certificate. The Contractor shall be paid interest on the overpayment, calculated from the date of payment to the date of repayment, at the rate specified in Clause 23.30

## **28. Securities**

**28.1** The Performance Security shall be provided to the Employer no later than the date specified in the Letter of Acceptance and shall be issued in an amount and form and by a reputable bank acceptable to the Employer, and denominated in Kenya Shillings. The Performance Security shall be valid until a date 30 days beyond the date of issue of the Certificate of Completion.

## **29. Day works**

**29.1** If applicable, the Day works rates in the Contractor's tender shall be used for small additional amounts of Work only when the Project Manager has given written instructions in advance for additional work to be paid for in that way.

**29.2** All work to be paid for as Day works shall be recorded by the Contractor on Forms approved by the Project Manager. Each completed form shall be verified and signed by the Project Manager within two days of the Work being done.

**29.3** The Contractor shall be paid for Day works subject to obtaining signed Day works forms.

### **30. Liability and Insurance**

**30.1** From the Start Date until the Defects Correction Certificate has been issued, the following are the Employer's risks:

- (a) The risk of personal injury, death or loss of or damage to property (excluding the Works, Plant, Materials and Equipment), which are due to;
  - (i) use or occupation of the Site by the Works or for the purpose of the Works, which is the unavoidable result of the Works, or
  - (ii) Negligence, breach of statutory duty or interference with any legal right by the Employer or by any person employed by or contracted to him except the Contractor.
- (b) The risk of damage to the Works, Plant, Materials, and Equipment to the extent that it is due to a fault of the Employer or in Employer's design, or due to war or radioactive contamination directly affecting the place where the Works are being executed.

**30.2** From the Completion Date until the Defects Correction Certificate has been issued, the risk of loss of or damage to the Works, Plant, and Materials is the Employer's risk except loss or damage due to;

- (a) a defect which existed on or before the Completion Date.
- (b) an event occurring before the Completion Date, which was not itself the Employer's risk
- (c) The activities of the Contractor on the Site after the Completion Date.

**30.3** From the Start Date until the Defects Correction Certificate has been issued, the risks of personal injury, death and loss of or damage to property (including, without limitation, the Works, Plant, Materials, and Equipment) which are not Employer's risk are Contractor's risks.

The Contractor shall provide, in the joint names of the Employer and the Contractor, insurance cover from the Start Date to the end of the Defects Liability Period, in the amounts stated in the Appendix to Conditions of Contract for the following events;

- (a) loss of or damage to the Works, Plant, and Materials;
- (b) loss of or damage to Equipment;

- (c) loss of or damage to property (except the Works, Plant, Materials, and Equipment) in connection with the Contract, and
- (d) Personal injury or death.

**30.4** Policies and certificates for insurance shall be delivered by the Contractor to the Project Manager for the Project Manager's approval before the Start Date. All such insurance shall provide for compensation required to rectify the loss or damage incurred.

**30.5** If the Contractor does not provide any of the policies and certificates required, the Employer may effect the insurance which the Contractor should have provided and recover the premiums from payments otherwise due to the Contractor or, if no payment is due, the payment of the premiums shall be a debt due.

**30.6** Alterations to the terms of insurance shall not be made without the approval of the Project Manager. Both parties shall comply with any conditions of insurance policies.

### **31. Completion and taking over**

**31.1** Upon deciding that the Works are complete, the Contractor shall issue a written request to the Project Manager to issue a Certificate of Completion of the Works. The Employer shall take over the Site and the Works within seven [7] days of the Project Manager's issuing a Certificate of Completion.

### **32. Final Account**

**32.1** The Contractor shall issue the Project Manager with a detailed account of the total amount that the Contractor considers payable to him by the Employer under the Contract before the end of the Defects Liability Period. The Project Manager shall issue a Defects Liability Certificate and certify any final payment that is due to the Contractor within 30 days of receiving the Contractor's account if it is correct and complete. If it is not, the Project Manager shall issue within 30 days a schedule that states the scope of the corrections or additions that are necessary. If the final account is still unsatisfactory after it has been resubmitted, the Project Manager shall decide on the amount payable to the Contractor and issue a Payment Certificate. The Employer shall pay the Contractor the amount due in the Final Certificate within 60 days.

### **33. Termination**

**33.1** The Employer or the Contractor may terminate the Contract if the other party causes a fundamental breach of the Contract. These



Fundamental breaches of Contract shall include, but shall not be limited to, the following;

- (a) the Contractor stops work for 30 days when no stoppage of work is shown on the current program and the stoppage has not been authorized by the Project Manager;
- (b) the Project Manager instructs the Contractor to delay the progress of the Works, and the instruction is not withdrawn within 30 days;
- (c) the Contractor is declared bankrupt or goes into liquidation other than for a reconstruction or amalgamation;
- (d) a payment certified by the Project Manager is not paid by the Employer to the Contractor within 30 days (for Interim Certificate) or 60 days (for Final Certificate) of issue.
- (e) the Project Manager gives notice that failure to correct a particular defect is a fundamental breach of Contract and the Contractor fails to correct it within a reasonable period of time determined by the Project Manager;
- (f) The Contractor does not maintain a security, which is required.

**33.2** When either party to the Contract gives notice of a breach of Contract to the Project Manager for a cause other than those listed under Clause 33.1 above, the Project Manager shall decide whether the breach is fundamental or not.

**33.3** Notwithstanding the above, the Employer may terminate the Contract for convenience.

**33.4** If the Contract is terminated, the Contractor shall stop work immediately, make the Site safe and secure, and leave the Site as soon as reasonably possible. The Project Manager shall immediately thereafter arrange for a meeting for the purpose of taking record of the Works executed and materials, goods, equipment and temporary buildings on Site.

#### **34. Payment Upon Termination**

**34.1** If the Contract is terminated because of a fundamental breach of Contract by the Contractor, the Project Manager shall issue a certificate for the value of the Work done and materials ordered and delivered to Site up to the date of the issue of the certificate. Additional liquidated damages shall not apply. If the total amount due to the Employer exceeds any payment due to the Contractor, the difference shall be a debt payable by the Contractor.

**34.2** If the Contract is terminated for the Employer's convenience or because of a fundamental breach of Contract by the Employer, the Project Manager shall issue a certificate for the value of the Work done, materials ordered, the reasonable cost of removal of equipment, repatriation of the Contractor's personnel employed solely on the Works, and the Contractor's costs of protecting and securing the Works.

**34.3** The Employer may employ and pay other persons to carry out and complete the Works and to rectify any defects and may enter upon the Works and use all materials on the Site, plant, equipment and temporary works.

**34.4** The Contractor shall, during the execution or after the completion of the Works under this clause remove from the Site as and when required, within such reasonable time as the Project Manager may in writing specify, any temporary buildings, plant, machinery, appliances, goods or materials belonging to or hired by him, and in default the Employer may (without being responsible for any loss or damage) remove and sell any such property of the Contractor, holding the proceeds less all costs incurred to the credit of the Contractor.

Until after completion of the Works under this clause the Employer shall not be bound by any other provision of this Contract to make any payment to the Contractor, but upon such completion as aforesaid and the verification within a reasonable time of the accounts therefore the Project Manager shall certify the amount of expenses properly incurred by the Employer and, if such amount added to the money paid to the Contractor before such determination exceeds the total amount which would have been payable on due completion in accordance with this Contract the difference shall be a debt payable to the Employer by the Contractor; and if the said amount added to the said money be less than the said total amount, the difference shall be a debt payable by the Employer to the Contractor.

## **35. Release from Performance**

**35.1** If the Contract is frustrated by the outbreak of war or by any other event entirely outside the control of either the Employer or the Contractor, the Project Manager shall certify that the Contract has been frustrated. The Contractor shall make the Site safe and stop Work as quickly as possible after receiving this certificate and shall be paid for all Work carried out and materials on site before receiving it.

## **36. Corrupt gifts and payments of commission**

The Contractor shall not;

- (a) Offer or give or agree to give to any person in the service of the

Employer any gift or consideration of any kind as an inducement or reward for doing or forbearing to do or for having done or forborne to do any act in relation to the obtaining or execution of this or any other Contract for the Employer or for showing or forbearing to show favor or disfavor to any person in relation to this or any other contract for the Employer.

- (b) Enter into this or any other contract with the Employer in connection with which commission has been paid or agreed to be paid by him or on his behalf or to his knowledge, unless before the Contract is made particulars of any such commission and of the terms and conditions of any agreement for the payment thereof have been disclosed in writing to the Employer.

Any breach of this Condition by the Contractor or by anyone employed by him or acting on his behalf (whether with or without the knowledge of the Contractor) shall be an offence under the provisions of the Public Procurement Regulations issued under The Exchequer and Audit Act Cap 412 of the Laws of Kenya.

### **37. Settlement Of Disputes**

**37.1** In case any dispute or difference shall arise between the Employer or the Project Manager on his behalf and the Contractor, either during the progress or after the completion or termination of the Works, such dispute shall be notified in writing by either party to the other with a request to submit it to arbitration and to concur in the appointment of an Arbitrator within thirty days of the notice. The dispute shall be referred to the arbitration and final decision of a person to be agreed between the parties. Failing agreement to concur in the appointment of an Arbitrator, the Arbitrator shall be appointed by the Chairman or Vice Chairman of any of the following professional institutions;

- (i) Architectural Association of Kenya
- (ii) Institute of Quantity Surveyors of Kenya
- (iii) Association of Consulting Engineers of Kenya
- (iv) Chartered Institute of Arbitrators (Kenya Branch)
- (v) Institution of Engineers of Kenya

On the request of the applying party. The institution written to first by the aggrieved party shall take precedence over all other institutions.

**37.2** The arbitration may be on the construction of this Contract or on any matter or thing of whatsoever nature arising thereunder or in

connection therewith, including any matter or thing left by this Contract to the discretion of the Project Manager, or the withholding by the Project Manager of any certificate to which the Contractor may claim to be entitled to or the measurement and valuation referred to in clause 23.0 of these conditions, or the rights and liabilities of the parties subsequent to the termination of Contract.

- 37.3** Provided that no arbitration proceedings shall be commenced on any dispute or difference where notice of a dispute or difference has not been given by the applying party within ninety days of the occurrence or discovery of the matter or issue giving rise to the dispute.
- 37.4** Notwithstanding the issue of a notice as stated above, the arbitration of such a dispute or difference shall not commence unless an attempt has in the first instance been made by the parties to settle such dispute or difference amicably with or without the assistance of third parties. Proof of such attempt shall be required.
- 37.5** Notwithstanding anything stated herein the following matters may be referred to arbitration before the practical completion of the Works or abandonment of the Works or termination of the Contract by either party:
- 37.5.1** The appointment of a replacement Project Manager upon the said person ceasing to act.
  - 37.5.2** Whether or not the issue of an instruction by the Project Manager is empowered by these Conditions.
  - 37.5.3** Whether or not a certificate has been improperly withheld or is not in accordance with these Conditions.
  - 37.5.4** Any dispute or difference arising in respect of war risks or war damage.
- 37.6** All other matters shall only be referred to arbitration after the completion or alleged completion of the Works or termination or alleged termination of the Contract, unless the Employer and the Contractor agree otherwise in writing.
- 37.7** The Arbitrator shall, without prejudice to the generality of his powers, have powers to direct such measurements, computations, tests or valuations as May in his opinion be desirable in order to determine the rights of the parties and assess and award any sums which ought to have been the subject of or included in any certificate.
- 37.8** The Arbitrator shall, without prejudice to the generality of his powers,

Have powers to open up, review and revise any certificate, opinion, decision, requirement or notice and to determine all matters in dispute which shall be submitted to him in the same manner as if no such certificate, opinion, decision requirement or notice had been given.

**37.9** The award of such Arbitrator shall be final and binding upon the parties.

## **SECTION V**

### **APPENDIX TO CONDITIONS OF CONTRACT**

THE EMPLOYER IS

Name: **KENYA WILDLIFE SERVICE**

Address: **P.O BOX 40241 NAIROBI**

Name of Authorised Representative:

**THE DIRECTOR GENERAL KENYA WILDLIFE SERVICE**

Telephone: **020-600800/6002345**

The Project Manager is

Name: **DEPUTY DIRECTOR COOPERATE SERVICE\_**

Address: **P.O. Box 40241, NAIROBI.**

Telephone: **(020) 6000800 Ext 2299**

**THE NAME AND IDENTIFICATION NUMBER OF THE CONTRACT IS  
KWS/OT/BF/59/2020-2021 TENDER FOR THE PROPOSED CONSTRUCTION OF  
20KM WILDLIFE ELECTRIC FENCE (LABOUR ONLY) AT MERU N.PARK-  
MERU/THARAKA NTHI COUNTIES.**

The commencement Date shall be **AGREED WITH THE PROJECT MANAGER**

The Intended Completion Date for the whole of the Works shall be  
**9 MONTHS AFTER DATE OF COMMENCEMENT**

The following documents also form part of the Contract:

**BILLS OF QUANTITIES, CONTRACT DRAWINGS AND ANY OTHER  
AUTHORIZED DRAWINGS WHICH MAY BE ISSUED**

The Contractor shall submit a revised program for the Works within **14** days of delivery of the Notification/Letter of Acceptance.

The Site Possession Date shall be **TWO WEEKS PRIOR TO COMMENCEMENT  
DATE**

The Site is located at Meru National Park- Meru/Tharaka Nthi Counties.

The Defects Liability period is 180 days.

Other Contractors, utilities etc that may be engaged by the Employer on the Site Include those for the execution of;

1. \_\_\_\_\_.
2. \_\_\_\_\_.
3. \_\_\_\_\_.
4. \_\_\_\_\_.

The minimum insurance covers shall be;

1. The minimum cover for insurance of the Works and of Plant and Materials in respect of the Contractor's faulty design is **NIL**
2. The minimum cover for loss or damage to Equipment is **NIL**
3. The minimum for insurance of other property is **KSH. 5,000,000.00**
4. The minimum cover for personal injury or death insurance
  - For the Contractor's employees is **KSH. 2,500,000.00**
  - And for other people is **KSH. 2,500,000.00**

The following events shall also be Compensation Events:

1. **NONE (ONLY AS LISTED IN CLAUSE 24 OF THE CONDITIONS OF CONTRACT)**
2. \_\_\_\_\_
3. \_\_\_\_\_
4. \_\_\_\_\_

The period between Program updates is 14 days.

The amount to be withheld for late submission of an updated Program is **EQUAL TO 25% OF CERTIFICATE**

The proportion of payments retained is 10 percent, subject to release of one moiety upon attainment of practical completion.

The Price Adjustment Clause **shall not** apply

The liquidated damages for the whole of the Works is **Kshs. 50,000.00** (per week)

The Performance Security shall be for the following minimum amounts equivalent as a percentage of the Contract Price TEN (**10**) percent (%)

The Completion Period for the Works is **9 MONTHS**

Advance Payment **MAY** be granted, in accordance clause 23.7 of conditions of contract



## SECTION VI – STANDARD FORMS

- (i) **Form of tender;** This form should be dully filled and signed by authorized person
- (ii) **Form of Agreement;** The form of agreement shall not be Completed by the tenderer at the time of submitting the tender, contract form shall be completed after contract award and should incorporate the accepted contract price
- (iii) **Form of Tender Security;** when required by the tender documents the tender shall provide tender security either in the form included herein or in another format acceptable to the employer
- (iv) **Performance Guarantee; the** performance security should not be completed by the tenderer at the time or tender preparation. Only successful tenderers will be required to provide performance security in the form provided herein or in another form acceptable to the employer
- (v)**Bank Guarantee for Advance Payment;** This form should not be completed by tenderers at the time for submission, it will be completed when advance payment is requested for by the successful bidder and agreed by the employer : this form then must be completed and signed by the authorized officials of the bank
- (vi) **Qualification Information;** This form must be completed fully and duly signed by the bidder
- (vii) **Tender Questionnaire** This form must be completed fully and duly signed by the bidder
- (viii) **Confidential Business Questionnaire** This form must be completed fully and duly signed by the bidder
- (ix) **Details of Sub-Contractors** This form must be completed fully and duly signed by the bidder when the employer has indicated that subcontractors shall be domestic
- (x)**declaration** of corrupt and fraudulent practices

**FORM OF TENDER**

TO: Director General Kenya Wildlife Service\_ [Name of Employer]  
\_\_\_\_\_ [Date]

\_\_\_\_\_  
[Name of Contract]

Dear Sir,

1. In accordance with the Conditions of Contract, Specifications, Drawings and Bills of Quantities for the execution of the above named Works, we, the undersigned offer to construct, install and complete such Works and remedy any defects therein for the sum of Kshs. \_\_\_\_\_ [Amount in figures] Kenya Shillings \_\_\_\_\_

\_\_\_\_\_  
[Amount in words]

- 1. We undertake, if our tender is accepted, to commence the Works as Soon as is reasonably possible after the receipt of the Project Manager’s notice to commence, and to complete the whole of the Works comprised in the Contract within the time stated in the Appendix to Conditions of Contract.
- 2. We agree to abide by this tender until \_\_\_\_\_ [Insert date], and it shall remain binding upon us and may be accepted at any time before that date.
- 3. Unless and until a formal Agreement is prepared and executed this tender together with your written notification/acceptance thereof, shall constitute a binding Contract between us.
- 4. We understand that you are not bound to accept the lowest or any tender you may receive.

Dated this \_\_\_\_\_ day of \_\_\_\_\_ 20\_\_\_\_\_

Signature \_\_\_\_\_ in the capacity of \_\_\_\_\_

duly authorized to sign tenders for and on behalf of \_\_\_\_\_ [Name of contractor]  
of \_\_\_\_\_ [Address of contractor]

Witness; Name \_\_\_\_\_

Address \_\_\_\_\_

Signature \_\_\_\_\_

**NOTIFICATION/LETTER OF ACCEPTANCE**  
**[Letterhead paper of the Employer]**

To: \_\_\_\_\_

\_\_\_\_\_

\_\_\_\_\_

\_\_\_\_\_

RE: Tender No. \_\_\_\_\_

Tender Name \_\_\_\_\_

This is to notify that the contract/s stated below under the above mentioned tender have been awarded to you, at a corrected bid price of kshs..... Subject to lapse of fourteen without request for review of award, by other bidders.

\_\_\_\_\_

1. Please acknowledge receipt of this letter of notification signifying your acceptance.
2. The contract/contracts shall be signed by the parties within 30 days of the date of this letter but not earlier than 14 days from the date of the letter.
3. Prior to signing of the agreement you will be expected to furnish the employer with the following as outlined in appendix to conditions of contract
  - An irrevocable and unconditional performance guarantee equivalent to 10% of the contract price.
  - Programme of works showing the general methods, arrangements, order timings and sequence for all activities of the works.
  - Insurance policies as listed in appendix to conditions of contract.
4. You may contact the officer(s) whose particulars appear below on the subject matter of this letter of notification of award.

(FULL PARTICULARS) \_\_\_\_\_

\_\_\_\_\_

SIGNED FOR ACCOUNTING OFFICER

## FORM OF AGREEMENT

THIS AGREEMENT, made the \_\_\_\_\_ day of \_\_\_\_\_ 20 \_\_\_\_\_  
between \_\_\_\_\_ of [or whose registered  
office is situated at] \_\_\_\_\_  
(Hereinafter called "the Employer") of the one part AND  
\_\_\_\_\_ of [or whose registered  
office is situated at] \_\_\_\_\_  
(Hereinafter called "the Contractor") of the other part.

WHEREAS THE Employer is desirous that the Contractor executes

\_\_\_\_\_ *(Name and identification number of Contract)* (Hereinafter called "the Works")  
located at \_\_\_\_\_ *[Place/location of the Works]* and the  
Employer has accepted the tender submitted by the Contractor for the execution  
and completion of such Works and the remedying of any defects therein for the  
Contract Price of Kshs \_\_\_\_\_ *[Amount in figures]*, Kenya  
Shillings \_\_\_\_\_ *[Amount in words]*.

NOW THIS AGREEMENT WITNESSETH as follows:

1. In this Agreement, words and expressions shall have the same meanings as are respectively assigned to them in the Conditions of Contract hereinafter referred to.
2. The following documents shall be deemed to form and shall be read and construed as part of this Agreement i.e.
  - (i) Letter of Acceptance
  - (ii) Form of Tender
  - (iii) Conditions of Contract Part I
  - (iv) Conditions of Contract Part II -Appendix to Conditions of Contract
  - (v) Specifications
  - (vi) Drawings
  - (vii) Priced Bills of Quantities
3. In consideration of the payments to be made by the Employer to the Contractor as hereinafter mentioned, the Contractor hereby

Covenants with the Employer to execute and complete the Works and remedy any defects therein in conformity in all respects with the provisions of the Contract.

1. The Employer hereby covenants to pay the Contractor in Consideration of the execution and completion of the Works and the Remediying of defects therein, the Contract Price or such other sum as may become payable under the provisions of the Contract at the times and in the manner prescribed by the Contract.

IN WITNESS whereof the parties thereto have caused this Agreement to be executed the day and year first before written.

The common Seal of \_\_\_\_\_

Was hereunto affixed in the presence of \_\_\_\_\_

Signed Sealed, and Delivered by the said \_\_\_\_\_

Binding Signature of Employer \_\_\_\_\_

In the presence of (i) Name \_\_\_\_\_

Address \_\_\_\_\_

Signature \_\_\_\_\_

Binding Signature of Contractor \_\_\_\_\_

In the presence of (i) Name \_\_\_\_\_

Address \_\_\_\_\_

Signature \_\_\_\_\_



**FORM OF TENDER SECURITY**

WHEREAS ..... (Hereinafter called "the Tenderer")  
has submitted his tender dated ..... for the construction of  
.....  
..... (Name of Contract)

KNOW ALL PEOPLE by these presents that WE ..... having our  
registered office at .....(hereinafter called "the Bank"), are bound unto  
.....(hereinafter called "the Employer") in the sum of Kshs.  
..... for which payment well and truly to be made to the said  
Employer, the Bank binds itself, its successors and assigns by these presents  
sealed with the Common Seal of the said Bank/insurance this ..... Day of  
.....20.....

THE CONDITIONS of this obligation are:

1. If after tender opening the tenderer withdraws his tender during the period  
of tender validity specified in the instructions to tenderers  
Or
2. If the tenderer, having been notified of the acceptance of his tender by the  
Employer during the period of tender validity:
  - (a) fails or refuses to execute the form of Agreement in accordance with  
the Instructions to Tenderers, if required; or
  - (b) fails or refuses to furnish the Performance Security, in accordance  
with the Instructions to Tenderers;

We undertake to pay to the Employer up to the above amount upon receipt  
of his first written demand, without the Employer having to substantiate  
his demand, provided that in his demand the Employer will note that the  
amount claimed by him is due to him, owing to the occurrence of one or  
both of the two conditions, specifying the occurred condition or conditions.

This guarantee will remain in force up to and including thirty (30) days  
after the period of tender validity, and any demand in respect thereof  
should reach the Bank not later than the said date.

\_\_\_\_\_  
[Date ]

\_\_\_\_\_  
[signature of the Bank/insurance]

\_\_\_\_\_  
[Witness]

\_\_\_\_\_  
[Seal]

## **PERFORMANCE BANK GUARANTEE**

To: \_\_\_\_\_ (Name of Employer) \_\_\_\_\_ (Date)  
\_\_\_\_\_ (Address of Employer)

Dear Sir,

WHEREAS \_\_\_\_\_ (hereinafter called "the Contractor") has undertaken, in pursuance of Contract No. \_\_\_\_\_ dated \_\_\_\_\_ to execute \_\_\_\_\_ (hereinafter called "the Works");

AND WHEREAS it has been stipulated by you in the said Contract that the Contractor shall furnish you with a Bank Guarantee by a recognized bank for the sum specified therein as security for compliance with his obligations in accordance with the Contract;

AND WHEREAS we have agreed to give the Contractor such a Bank Guarantee:

NOW THEREFORE we hereby affirm that we are the Guarantor and responsible to you, on behalf of the Contractor, up to a total of Kshs. \_\_\_\_\_ (amount of Guarantee in figures) Kenya Shillings \_\_\_\_\_ (amount of Guarantee in words), and we undertake to pay you, upon your first written demand and without cavil or argument, any sum or sums within the limits of Kenya Shillings \_\_\_\_\_ (amount of Guarantee in words) as aforesaid without your needing to prove or to show grounds or reasons for your demand for the sum specified therein.

We hereby waive the necessity of your demanding the said debt from the Contractor before presenting us with the demand.

We further agree that no change, addition or other modification of the terms of the Contract or of the Works to be performed thereunder or of any of the Contract documents which may be made between you and the Contractor shall in any way release us from any liability under this Guarantee, and we hereby waive notice of any change, addition, or modification.

This guarantee shall be valid until the date of issue of the Certificate of practical Completion.

SIGNATURE AND SEAL OF THE GUARANTOR \_\_\_\_\_

Name of guarantor \_\_\_\_\_

Address \_\_\_\_\_

Date \_\_\_\_\_



**BANK GUARANTEE FOR ADVANCE PAYMENT**

To: \_\_\_\_\_ [name of Employer] \_\_\_\_\_ (Date)  
\_\_\_\_\_ [address of Employer]

Gentlemen,

Ref: \_\_\_\_\_ [name of Contract]

In accordance with the provisions of the Conditions of Contract of the above-mentioned Contract, We, \_\_\_\_\_ [name and Address of Contractor] (hereinafter called "the Contractor") shall deposit with \_\_\_\_\_ [name of Employer] a bank guarantee to guarantee his proper and faithful performance under the said Contract in an amount of Kshs. \_\_\_\_\_ [amount of Guarantee in figures] Kenya Shillings \_\_\_\_\_ [amount of Guarantee in words].

We, \_\_\_\_\_ [bank or financial institution], as instructed by the Contractor, agree unconditionally and irrevocably to guarantee as primary obligator and not as Surety merely, the payment to \_\_\_\_\_ [name of Employer] on his first demand without whatsoever right of objection on our part and without his first claim to the Contractor, in the amount not exceeding Kshs \_\_\_\_\_ [amount of Guarantee in figures] Kenya Shillings \_\_\_\_\_ [amount of Guarantee in words], such amount to be reduced periodically by the amounts recovered by you from the proceeds of the Contract.

We further agree that no change or addition to or other modification of the terms of the Contract or of the Works to be performed thereunder or of any of the Contract documents which may be made between \_\_\_\_\_ [name of Employer] and the Contractor, shall in any way release us from any liability under this guarantee, and we hereby waive notice of any such change, addition or modification.

No drawing may be made by you under this guarantee until we have received notice in writing from you that an advance payment of the amount listed above has been paid to the Contractor pursuant to the Contract.

This guarantee shall remain valid and in full effect from the date of the Advance payment under the Contract until \_\_\_\_\_ (name of Employer) receives full payment of the same amount from the Contract.

Yours faithfully,

Signature and Seal \_\_\_\_\_

Name of the Bank or financial institution \_\_\_\_\_

Address \_\_\_\_\_

Date \_\_\_\_\_

Witness: Name: \_\_\_\_\_

Address: \_\_\_\_\_

Signature: \_\_\_\_\_

Date: \_\_\_\_\_

# QUALIFICATION INFORMATION

## 1. Individual Tenderers or Individual Members of Joint Ventures

1.1 Constitution or legal status of tenderer (attach copy or Incorporation Certificate);

Place of registration: \_\_\_\_\_

Principal place of business \_\_\_\_\_

Power of attorney of signatory of tender \_\_\_\_\_

1.2 Total annual volume of construction work performed in the last five years

Year	Volume	
	Currency	Value

1.3 Work performed as Main Contractor on works of a similar nature and volume over the last five years. Also list details of work under way or committed, including expected completion date.

Project name	Name of client and contact person	Type of work performed and year of completion	Value of Contract
_____	_____	_____	_____
_____	_____	_____	_____
_____	_____	_____	_____

1.4 Major items of Contractor's Equipment proposed for carrying out the Works. List all information requested below.

Item of Equipment	Description, Make and age (years)	Condition(new, good, poor) and number available	Owned, leased (from whom?), or to be purchased (from whom?)
_____	_____	_____	
_____	_____	_____	
_____	_____	_____	
(etc.)			

1.5 Qualifications and experience of key personnel proposed for administration and execution of the Contract. Attach biographical data.

Position	Name	Years of experience (general)	Years of experience in proposed position
Project Manager, Site agent, foreman	_____	_____	_____
_____	_____	_____	_____
_____	_____	_____	_____
(etc.)			

1.6 Financial reports for the last two years: balance sheets, profit and loss statements, auditor's reports, etc OR bank statement for the last 24 months. List below and attach copies.

\_\_\_\_\_

\_\_\_\_\_

1.7 Evidence of access to financial resources to meet the qualification requirements: cash in hand, lines of credit, etc. List below and attach copies of supportive documents.

\_\_\_\_\_

\_\_\_\_\_

\_\_\_\_\_

1.8 Name, address and telephone, telex and facsimile numbers of banks that may provide reference if contacted by the Employer.

\_\_\_\_\_

\_\_\_\_\_

1.9 Statement of compliance with the requirements of Clause 1.2 of the Instructions to Tenderers.

\_\_\_\_\_

\_\_\_\_\_

\_\_\_\_\_

1.10 Proposed program (work method and schedule) for the whole of the Works and cash flow projection

## **2 Joint Ventures**

- 2.4 The information listed in 1.1 – 1.10 above shall be provided for each partner of the joint venture.
- 2.5 The information required in 1.11 above shall be provided for the joint venture.
- 2.6 Attach the power of attorney of the signatory(ies) of the tender authorizing signature of the tender on behalf of the joint venture
- 2.7 Attach the Agreement among all partners of the joint venture ( and which is legally binding on all partners), which shows that:
  - a) all partners shall be jointly and severally liable for the execution of the Contract in accordance with the Contract terms;
  - b) one of the partners will be nominated as being in charge, authorized to incur liabilities and receive instructions for and on behalf of any and all partners of the joint venture; and
  - c) the execution of the entire Contract, including payment, shall be done exclusively with the partner in charge.

## TENDER QUESTIONNAIRE

Please fill in block letters.

1. Full names of tenderer

.....

2. Full address of tenderer to which tender correspondence is to be sent  
(unless an agent has been appointed below)

.....

3. Telephone number (s) of tenderer

.....

4. Telex address of tenderer

.....

5. Name of tenderer's representative to be contacted on matters of the tender  
during the tender period

.....

6. Details of tenderer's nominated agent (if any) to receive tender notices.  
This is essential if the tenderer does not have his registered address in  
Kenya (name, address, telephone, telex)

.....

.....

\_\_\_\_\_  
Signature of Tenderer

Make copy and deliver to : \_\_\_\_\_ ( *Name of Employer* )

**CONFIDENTIAL BUSINESS QUESTIONNAIRE**

You are requested to give the particulars indicated in Part 1 and either Part 2 (a), 2 (b) or 2 (c) and 2 (d) whichever applies to your type of business.

You are advised that it is a serious offence to give false information on this Form.

*Part 1 – General*

Business Name .....

Location of business premises; Country/Town.....

Plot No..... Street/Road .....

Postal Address..... Tel No.....

Nature of Business.....

Current Trade License No..... Expiring date.....

Maximum value of business which you can handle at any time: Ksh .....

Name of your bankers.....

Branch.....

*Part 2 (a) – Sole Proprietor*

Your name in full..... Age.....

Nationality..... Country of Origin.....

\*Citizenship details .....

*Part 2 (b) – Partnership*

Give details of partners as follows:

	<i>Name in full</i>	<i>Nationality</i>	<i>Citizenship Details</i>	<i>Shares</i>
1.	.....	.....	.....	.....
2.	.....	.....	.....	.....
3.	.....	.....	.....	.....

**Part 2(c) – Registered Company:**

Private or public.....

State the nominal and issued capital of the Company-

Nominal Kshs.....

Issued Kshs.....

Give details of all directors as follows:

Name in full.    Nationality.    Citizenship Details\*.    Shares.

1.  
.....

2.  
.....

3.  
.....

4.  
.....

**Part 2(d) – Interest in the Firm:**

Is there any person / persons in .....(Name of Employer) who has interest in this firm? Yes/No.....(Delete as necessary)

I certify that the information given above is correct.

.....  
(Title)

.....  
(Signature)

.....  
(Date)

- Attach proof of citizenship



**DETAILS OF SUB-CONTRACTORS**

If the Tenderer wishes to sublet any portions of the Works under any heading, he must give below details of the sub-contractors he intends to employ for each portion.

Failure to comply with this requirement may invalidate the tender.

(1) Portion of Works to be sublet: .....

(i) Full name of Sub-contractor and address of head office: .....

.....

(i) Sub-contractor's experience of similar works carried out in the last 3 years with Contract value: .....

.....

.....

(2) Portion of Works to sublet: .....

(i) Full name of sub-contractor and address of head office: .....

.....

.....

(i) Sub-contractor's experience of similar works carried out in the last 3 years with contract value: .....

.....

\_\_\_\_\_  
[Signature of Tenderer]

\_\_\_\_\_  
Date

**DECLARATION FORM**

Date: .....

To: DIRECTOR GENERAL  
KENYA WILDLIFE SERVICE  
P. O. BOX 40241-00100  
NAIROBI

The Bidder (name and address).....

.....

.....

.....

.....

.....

Declares the following:

- (a) Has not been debarred from participating in public procurement.
- (b) Has not been involved in and will not be involved in corrupt and fraudulent practices regarding public procurement

(Signature) ..... (Date).....

Official Stamp:.....

(To be signed by authorized representative and officially stamped)

---

## **SECTION VII: DESIGN AND SPECIFICATIONS**

### **1.0 GENERAL SPECIFICATIONS**

The following specifications shall apply in this project:

- a) Ministry of Public Works Standard Specification for roads and Bridge construction
- b) MOPW specification for Building construction
- c) Specification for steel wires and wire products used for fencing (KS 06-261-1987)
- d) Specification for preservation of Timber (KS 02-94-1985)
- e) This special specification

### **1.1 CLEARING OF THE FENCE ALIGNMENT**

Within a corridor of Six (6)m width along the community/Park boundary will be the fence alignment to be cleared of all vegetation and top soil up to a depth of 200mm cut away and disposed within the eased area.

The ground within the corridor shall be leveled by grading, set so as to leave a 3m width of the corridor to either side of fence to serve as fire break and service road and sloped as is most suitable according to terrain so as to allow for surface drainage.

### **1.2 DRAINAGE AND EARTHWORKS**

Where necessary, catch water, cutoff and side/miter drains shall be cut with an earth moving equipment or human labor to deviate off run off from the service road. Simple drainage structures (culverts or drifts) shall be constructed where identified by the supervisor.

Where necessary forming the appropriate cross sections shall involve cutting and filling and in such cases the fill shall be compacted in layers to 95% MDD ASHTO T99 in accordance with the Standard Specification for road and Bridge Construction.

### **2.0 FENCE DESIGN.**

The fence shall be of Intermediate Design. The electric fence shall consist of Eight (8) strands over and above the ground. There shall be Six (6) live wires and two (2) earth running wires passing through insulators on the forest side of the post. The bottom earth wire shall be looped to the upper earth wires. At 200m interval, the wire shall be attached to a 2m earth peg with a joint clamp. All live wires shall be attached to strain insulators at strainer assemblies and tied by joint clamps and looped across king post to the next wire tied in the same way. Galvanized staples shall be used to attach earth wires and insulators to the posts. All wires shall be strained to a tension of 180kg. Standard galvanized joint clamps shall be used to join the wire along the main fence line and at corners

where looping shall be necessary. All joints shall be tight and of figure 8 or reef knot joint.

## **2.1 POSTS**

### **Line Posts**

All line posts shall have a minimum diameter of 150mm and height of 3050mm and shall be spaced at 10,000mm on level ground (slope <5%). The spacing will be reduced to 8000mm on sloppy and undulating terrain (slope of >5%). They shall have a smooth and cylindrical surface free of knots and cracks.

The posts shall be set in holes 450mm wide by 950mm in depth in such a manner that 2100mm will be above the ground. The posts shall be embedded all round in 1.3.6 concrete with a cover of 150mm in swampy or rock areas.

### **Strainer Posts**

Strainer shall be build where there is change in the fence alignment both horizontal and vertical change (corner or depression) and at every 200m on a straight line.

The strainer assembly consists of the King posts, 2No. Strainer posts and two struts a shown in fig. 2. They shall all be 150 – 175mm diameter 3150mm in height. The strainer posts shall be connected to the King posts by a 2000mm long 150mm diameter strut (side arms) Fastening shall be by means of ordinary galvanized wire nails 125mm long. 4.0mm heavily galvanized soft wire shall be tide in 4 rounds diagonally from the supporter posts to the bottom of the King posts and twined to form a stay wire and held in place by use of 50mm heavily galvanized staple nails nailed to hold in place. The posts shall all be embedded all round in 1.3.6 concrete in a pre-dug hole measuring 525mm diameter and 1050mm in depth. They shall be set in such a way that 2100mm is above ground level. A minimum of 4days will be allowed for the curing of the concrete during which period no external forces shall be exerted on the posts.

## **2.2 WIRE .**

### **2.2.1 Plain Wire**

#### **i) Live wire**

Plain wire to be used for live wire shall be High Tensile Steel wire 2.5mm diameter heavily galvanized to a zinc coating of not less than 280gm/m<sup>2</sup> and of steel class BS 1044 or BS 1065 and tensile strength of between 1200 and 1400N. The wire shall be strained on each end on porcelain strain insulator and run through W-plastic insulators nailed to posts by use of deep sunk heavily galvanized 2" U-nails.

#### **ii)Earth Wire**

The earth wires shall be as the live wires above.

## **3.0 ELECTRIFICATION**

### **i) Power Source**

Source of power shall be from the Kenya Power Mains grid where available and where not, Solar/battery power shall be used. One Energizer of at least 58joules

stored energy mains powered or Solar/ Battery Energizer of at least 16 joules stored energy shall be used for every 8km of fence. The electrics shall be housed in an Energizer room built at intervals of 8km where one room can power two sections running to opposite directions. The houses may have provision for accommodation for fence attendants who will take care of the electrics and maintenance of the fence.

i) **Double Insulated Lead wires**

Lead Wire (Under gate cable) in PVC pipe will carry power from the energizer house to the fence and the same to be used where there is any crossing like across gates, roads, grids, bridges over pass, under pass. At every passage there will be a cut out switch. The lead out cable shall be of 2.5mm diameter, double insulated in heavy duty polyethylene UV protected PVC material, put through a 25mm heavy gauge PVC pipe and laid 500mm below ground level. U-bends shall be constructed using bends, elbows and unions at points where the lead out wire goes into or comes out of the ground for the bend to face downwards.

ii) **Lightening Diverter**

At every energizer installation there will be a set of Lightening diverter installation for protection of the electrics. The diverter shall have a well-constructed loop and choke assembly complete with PVC or unlimber supporter.

iii) **Earthing for Energizer**

This shall be identical to earthing for the fence but shall be provided separately using 5No. Earth pegs set at 2m spacing. At the same area there will be earthing for the lightening arrester which will consist of 6No. Pegs also at interval of 2m.

iv) **Crossing Gorges**

In Areas with gorges and dry river beds, there shall be a strainer assembly on either side at a height of 6m above the highest water level. The overhead fence across the valley shall be of the six electrified wires only without the mesh wire. In deep gorges and valleys fence chain danglers will be suspended under the fence to stop elephants from crossing. The number and length of the danglers will be determined by the shape and depth of the valley.

A flood gate controller will be installed at every river, gorge or valley crossing.

#### **4.0 GATES**

Gates shall be constructed at strategic points to be determined on site.

## **5.0 DETAIL SPECIFICATIONS**

### **Posts**

#### **a) Wooden Posts – Strainers**

- i) All wooden posts shall be of hardwood wattle or eucalyptus.
- ii) Pressure treated in cultured copper chrome arsenate {CCA}{tonality}C to the  
Chemical penetration of at least 1” (25mm)
- iii) Size shall be at least 6-7” diameter, length 11ft
- iv) Knot free and split free
- v) Bound at top and bottom by a HTS wire 2.5mm four times and stapled by  
1” Staple nail.
- vi) Not more than one year’s Kenya Bureau of Standards Test Certificate  
required bearing bidders Name-.

#### **(b) Wooden Posts - Line posts**

- i) All wooden posts shall be of hardwood wattle or eucalyptus.
- ii) Pressure treated in copper chrome arsenate {CCA}{tonality}C to the  
chemical penetration of at least 1” (25mm)
- iii) Size shall be at least 5-6” diameter, length 10ft.
- iv) Knot free and split free
- v) Bound at top and bottom by a HTS wire 2.5mm four times and stapled by  
1” staple nail.
- vi) Not more than one year’s Kenya Bureau of Standards Test Certificate  
required bearing bidders Name.

### **c) Wires**

#### **i) Plain Wire 2.5mm HTS**

Plain wire to be used shall be: -

- i) High tensile steel wire of steel class BS 1044 or BS 1065
- ii) Size for live and earth wires shall be 2.5mm diameter with a tolerance
- iii) of 0.02mm.
- iv) Shall have a tensile strength of 1200-1400N
- v) Shall have a weight of zinc coating of not less than 280gm/m<sup>2</sup>
- vi) Gauge 12.5
- vii) Not more than one year Kenya Bureau of Standards Test Certificate required.

#### **ii) Soft Wire/stay wire**

- i) Shall be of mild steel wire.
- ii) Shall have weight of zinc coating of not less than 280gm/m<sup>2</sup>
- iii) Kenya Bureau of Standards Test Certificate required
- iv) Size shall be **4.0mm** diameter mainly used for stay and cross wire on a Strainer Assembly.
- iv) Shall have tensile strength of not less than 500N

### **d) Staples Nails (U-nails)**

Staples (U-nails) shall be:

- i) Heavily galvanized wire nails
- ii) Long shank
- iii) 2 inches
- iv) Hot dipped.
- v) 4mm wire gauge.

### **e) Insulators**

#### **i) Line Insulators**

- i) W-Insulators
- ii) Polyethylene material
- iii) Open-face for good drainage
- iv) With holes for anchoring staples
- v) Made of UV protected polythene material
- (Vi) Strong jaws to withstand large horizontal and vertical movements.

#### **ii) Strain end Insulators**

- (I) Bull nose type
- (ii) Porcelain material
- (iii) Fire resistant
- (iv) Long tracking distance
- (v) High quality white glaze finish

#### **iii) Corner and Line Insulator**

- (I) Reel round Insulator
- (ii) Porcelain material
- (iii) Fire resistant
- (iv) High quality glaze finish
- (

**f) Energizers**

**i) Solar Powered energizers**

- i) Shall be fully modular
- ii) 16 joules stored energy
- iii) In built lightening protection

**ii) Main's energizers**

- i) Shall be fully modular
- ii) At least 58 joules stored energy
- iii) In built lightening protection
- iv) Remote ON/OFF operation capability.
- v) Must have a status LED.
- vi) Capable of integration with
  - Alarm system
  - Remote and fault finder
  - SMS Energizer controller
  - Fence monitor.

**g) Others**

**i) Lightning Diverter/ Arrester**

At all places where energizers are installed there shall be a lightning diverter

(I) Standard lightening diverter is completed with spiral wire earthing system connection.

- (ii) Adjustable to suit any module.
- (iii) shall be able to divert multiple lightning strikes to the ground(earth)
- iv) Size 90x100x60mm

**ii) Earth peg**

- (I) 2mx20mm diameter GI pipe class C
- (ii) With a heavily galvanized Joint clamp 200mm below the upper tip
- (iii) Heavily galvanized not less than 500gm/Sq m
- (iv) Kenya Bureau of Standards Test Certificate required

**iii) Solar Panel - 140Watts Solar Panels**

**d) Solar Battery**

Shall be:

Clause	Specification	Compliance Values /Brand/ Country of Origin to be Printed in this Column
I	Brochures/Catalogue/Data Sheet of the equipment shall be submitted with the quotation response <b>highlighting</b> the particular product on offer in the brochures. Bids without technical brochures shall <b>NOT</b> be evaluated.	
II	Lead Acid Flooded Solar Battery	
III	Battery Capacity - 12V/≥100Ah Lead Acid Flooded / Gel with catalyst Battery at <b>C20 Rating</b>	



IV	Deep Cycle Solar Battery Technology.	
V	Dry Charged / Maintenance free	
VI	Plate Design - Tubular Plates	
VII	Battery Casing shall be <b>Transparent (Clear Glass)</b> with Minimum/Maximum electrolyte level markings for clear <b>Electrolyte Level</b> Inspection and Maintenance.	
VIII	Battery acid of the correct specific gravity recommended by the manufacturer shall be supplied separately in plastic containers for ease of transportation and safety.	
IX	Warranty Period – Minimum 2 Years	

#### e) Charge Controller/regulator

Clause	Specification	Compliance Values/Brand/ Country of Origin to be Printed in this Column
I	Brochures/Catalogue/Data Sheet of the equipment shall be submitted with the quotation response <b>highlighting</b> the particular product on offer in the brochures. Bids without technical brochures shall <b>NOT</b> be evaluated.	
II	<ul style="list-style-type: none"> <li>12V/30A Solar Charge Controller with LCD display / Digital Meter that will display; Charging/Load Current, Battery/Solar Voltage</li> </ul>	
III	System Voltage ⇒12V/24 AutoDetect	
IV	Maximum Output Current ⇒30A Continuous Rating	
V	Electronic Protections ⇒Reverse Current at Night	
VI	Charging Regulation ⇒Bulk, Absorption, Float, Equalize	
VII	Technology ⇒Trak Star Maximum Power Point Tracking (MPPT) Charge Controller	
VIII	Operating temperature ⇒- 40°C to +60°C	
IX	Warranty Period ⇒Minimum 5 Years	

#### f) Hatari/Warning/Danger signs

- (I) Shall be made of UV protected material
- (ii) Size 247mmx147mmx3mm
- (iii) Color shall be bright yellow
- (iv) Inscription written in black **“ELECTRIC FENCE”**
- (v) Eligible with lettering not less than 25mm in height
- (vi) A legal requirement for all electric installations

#### g) Spring Gates

- (I) Shall be bright colored spiral wire (**white**)
- (ii) Shall have Plastic **bright colored** handle
- (iii) Metal's paring shall be galvanized and powder coated white
- (iv) Shall have an insulated gate handle
- (v) Shall have a galvanized non-turning hook that retracts to hanging

position. (550mm)

**h) Joint Clamp**

- (I) Shall be made of Aluminum or Mild steel.
- (ii) Shall have zinc coating of not less than 500gm/Sqm)
- (iii) Kenya Bureau of Standards Test Certificate required.
- (iv) With space for wire grip
- (v) L-shaped
- (vi) Size 28mmx25mmx20mm (WHD)

**I) Barbed Wire**

Shall be:

- i)** Heavily galvanized
- ii)** 25Kg Roll.

**j) Cut out switch for electric fencing**

Shall be:

- i) Single live wire
- ii) Shall have a Turn ON/OFF selector
- iii) Must have protected contacts to eliminate shocks.
- iv) Shall be weather proof and fully sealed.
- v) Shall be made of UV stabilized plastic
- vi) Shall have electrical contacts to handle over 10,000 Volts

**k) Multi-Units**

Shall be:

- i) 3600mm diameter
- ii) Round and Veraval
- iii) 0.5mm thick sides and roof material respectively.

**l) Digital voltmeter**

Shall be:

- i) Electric Fence Digital Voltmeter.
- ii) Sealed and water proof.
- iii) Made of Polycarbonate case
- iv) Capable of displaying voltage increments along the fence line
- v) Capable of displaying High Voltage pulse voltage.
- vi) Shall Auto turn -On
- vii) Capable of displaying low battery condition
- viii) Able to measure earth voltages
- ix) Has replaceable lead (1Meter) and clips
- x) Size 66mm x 125mm x 25mm

**m) Fencing pliers**

Shall be:

- i) Side cutting pliers
- ii) Shall be insulated to prevent shock
- iii) Shall have "side by side" jaws with wire grip groove.
- iv) Size 215mm x 70mm x 25mm

**n) Lead wire (Under gate cables)**

- (I) Shall be double insulated in tough polyethylene insulating material
- (ii) Shall have a lead wire of 2.5mm diameter
- (iii) Shall have a lead wire of copper or aluminum.
- (iv) Shall have resistance of less than 350 ohms per km
- (v) Insulator should be greater than 20Kv

## **6.0 FENCE CODE OF ETHICS AND PRACTICE.**

- a. Electric fences shall be so installed and operated and they cause no danger to persons, animals or surroundings.
- b. Electric fences shall not be supplied from more than one energizer.
- c. For any two different electric fences the distance between the wires and the connecting leads shall be at least 2m apart. If the gap is to be closed then a non- conductive insulating material shall be used.
- d. Barbed wire shall not be used in electric fences.
- e. All installed electric fences shall be visibly identified warning signs securely fastened to posts or firmly clamped to the fence wire at frequent intervals of at least 100m. (The size of the plate shall be at least 200mmx100mm. the inscription shall be legible and any lettering shall have a height of at least 25mm).
- f. If it is necessary to cross a public pathway, the cornered road authority shall be advised and in any case the lead wire across shall be at least 5.45m high.
- g. Fence wires and connecting leads shall not be fixed to poles used for overhead power lines, telephone, or telegraph lines, and in any case if such poles are to be interfered with, the relevant electricity supply utility company or controlling authority must provide permission.
- h. Inside buildings, connecting lead wires shall be placed through PVC pipes and through special insulated lead wires (under gate cables).
- i. The electrode of the earth system of the fence shall preferably be installed at a spot where the soil is damp to ensure good contact. The electrode shall penetrate the ground to a depth of at least 1.0m for mains powered energizers and 2m for solar battery powered energizers.
- j. Energizers shall be installed under cover out of reach of children in a place free from mechanical damage and away from inflammable materials; solar powered energizers are best placed in a secluded area with no shadows on the equator side and the panels to face towards the equator.
- k. All wire connections shall be joined by figure eight or reef knot joints and joint clamps shall be used for all permanent connections.
- l. All wire shall be stored away from corrosives, fertilizer lime, acids and any other chemical and shall not be dropped on any hard materials, to avoid peeling off of the galvanizing material if possible, use wire dispensing during construction.
- m. Keep electrified wires well away from radio aerials.
- n. Local body approval and advice regarding local regulations shall be sought before constructing any electric fence near railways, sock routes, pipelines, telephone lines, telegraphic lines, power lines, etc.
- o. The number of gates to be constructed shall be kept to the minimum. Gates shall only be constructed for (I) operational needs by KWS community needs based on management agreement between the

community and Kenya Wildlife Service. All gates shall be manned by Kenya Wildlife Service

- p. Because the fence is in the Meru.N.Park, construction must follow the laid down procedures.

## **SECTION VIII**

### **PREAMBLES & PRELIMINARIES**

1. The contract shall be for the **LABOUR ONLY** works, as described in the bills of quantities
2. The bidder shall fill in prices for all items of works described in the specifications and drawings. Items for which no price is entered by the bidder shall be deemed to have been covered by other prices in the bills of quantities.
3. The bidder shall bear all costs associated with preparation and submission of the bids
4. The prices quoted by the bidder shall not be subject to adjustment during performance of the contract.
5. The preliminary section of the tender document shall be keenly and consistently priced and shall not be expected to exceed 10% of bid sum in any event
6. All prices inserted by the bidder **shall be deemed inclusive** of all government taxes payable 28 days prior to submission of tender
7. Abbreviations

<b>C.M.</b>	Shall mean cubic metre
<b>S.M.</b>	Shall mean square metre
<b>L.M.</b>	Shall mean linear metre
<b>MM</b>	Shall mean Millimetre
<b>Kg.</b>	Shall mean Kilogramme
<b>No.</b>	Shall mean Number
<b>Prs.</b>	Shall mean Pairs
<b>B.S.</b>	Shall mean the British Standard Specification Published by the British Standards Institution, 2 Park Street, London W.I., England.
<b>Ditto</b>	Shall mean the whole of the preceding description except as qualified in the description in which it occurs.
<b>m.s.</b>	Shall mean measured separately.

***a.b.d***

Shall mean as before described.

**SECTION V PRELIMINARIES**

<b>Item No.</b>	<b><u>Definition of Terms</u></b>	<b><u>Kshs</u></b>
A.	<p>Wherever used hereinafter and in all Contract Documents the following definitions of terms shall apply: -</p> <p><b>Employer:</b> The term “Employer” shall mean <b>Kenya Wildlife Service</b>, P.O. Box 40241 - 00100, NAIROBI.</p> <p><b>Contractor:</b> The term “Contractor” shall mean the person, partnership, firm or company, whose tender for the Works has been accepted and who has, have, will sign(ed) this Contract and shall include his or their heirs, executors, administrators, assigns, successors and duly appointed representatives.</p> <p><b>Engineer:</b> <b>The term “Engineer” shall mean The Party stipulated in the Appendix to Bid</b></p> <p><b>Works:</b> The term “the works” shall mean all or any portion of the work, materials and articles whether the same are being manufactured or prepared, which are to be used in the execution of this Contract and whether the same be on the site of the work or not. It shall also be deemed to include the work of all Sub-Contractors and of all variations.</p> <p><b>Contract:</b> The term “the Contract” shall mean the Form of Tender, Articles of Agreement and Conditions of Contract, Form of Bond, Drawings and priced and signed Bills of Quantities.</p>	
B	<p><b>Description of site</b></p> <p>The site of the works is situated in Meru <b>N.Park along Uri river</b></p>	
C	<p><b>Description of works and scope of contract</b></p> <p><i>The Works to be executed under this Contract shall comprise of the following:</i></p> <ol style="list-style-type: none"> <li><i>1) Clearing of vegetation; earthworks, compaction, drainages</i></li> <li><i>2) Pegging; Excavation of holes to receive posts;</i></li> <li><i>3) Construction of assemblies, corner and line posts</i></li> </ol>	
	<b>Amount Carried to collection</b>	

Item No.	Particular preliminaries can't	<u>KShs.</u>
	4) Ramming of posts;_ 5) <i>Tying of Strainers and reels;</i> 6) <i>Fixing of W – Insulators;</i> 7) <i>Straining of wires;</i> 8) <i>Fixing of spring gates to gate openings</i> 9) <i>Construction of energizer houses;</i> 10) <i>Powering;</i> 11) <i>Clearing 3m on either side for fire break/service road</i> 12) <i>Testing of voltages along stretches of fence line</i> 13) <i>Handing over and Commissioning</i>	
A.	<p align="center">–</p> <p><b>Form of Agreement</b></p> <p>The Contractor shall be required to enter into a contract which shall be the current Form of Standard bidding document, “the conditions of contract for works of Civil Engineering Construction as published by FIDIC – Fourth Edition (1987)”. The Contractor shall be deemed to have read and acquainted himself with the said Conditions.</p>	
B.	<p><b>Conditions of Contract</b></p> <p>The contractor’s attention is drawn to the text of the said conditions of contract and he is to allow in his prices for any costs arising therefrom or in connection therewith.</p>	
C.	<p><b><u>Government taxes</u></b></p> <p>The tender sum <b><u>shall be deemed inclusive</u></b> of all government taxes payable 30 days prior to submission of tender. The employer shall comply with all legal provisions requiring deduction and remittance of such taxes to the Kenya Revenue Authority. <b><u>No claims shall be entertained from the contractor for noncompliance with this clause</u></b></p>	
D	<p><b>Measurements</b></p> <p>In the event of any discrepancies arising between the Bills of Quantities and the actual works, the site measurements shall generally take precedence. However, such discrepancies between any contract documents shall immediately be referred to the Engineer. The discrepancies shall then be treated as a</p>	
	<b>Amount Carried to collection</b>	

Item No.	<b>GENERAL PRELIMINARIES</b>	<b><u>KShs</u></b>
A.	<p><b>Sufficiency of tender</b></p> <p>The Contractor shall be deemed to have satisfied himself before tendering as to the correctness and sufficiency of his Tender for the works and of the rates and prices stated in the priced bills of quantities which rates and prices shall cover all his obligations under the contract and all matters and things necessary for the proper completion and maintenance of the Works.</p>	
B.	<p><b>Site works</b></p> <p>The contractor shall allow for among other things the following: -</p> <ul style="list-style-type: none"> <li>- Providing all materials, tools, plant and scaffolding</li> <li>- Complying with local authority regulations and by-laws</li> <li>- Providing adequate supervision</li> <li>- Transporting materials and workmen etc., to and from the site. No erection of labor camps shall be allowed on site.</li> <li>- Complying with all relevant Acts governing construction works and employment</li> <li>- Security for the works, stores etc.</li> <li>- Cleaning and making good damages to all access roads</li> <li>- Complying with Police regulations</li> <li>- Providing and maintaining a progress schedule</li> <li>- Overtime working</li> <li>- Testing of materials as required</li> <li>- Sanitation of the works</li> <li>- Protecting the works and all plant and materials</li> <li>- Cleaning the site on completion</li> <li>- Training Levy</li> <li>- Maintaining adequate site record and diary</li> <li>- Site safety and first aid facilities</li> <li>- Standards Levy</li> <li>- Site clearance</li> </ul>	<p style="text-align: center;">-</p> <p>1. 2,000,000</p> <p>2.</p> <p>3.</p> <p>4. 300,000</p>
	<b>Amount Carried to collection</b>	



<b>Item No.</b>	<b>General preliminaries (CON'T)</b>	<b><u>KShs</u></b>
A.	<p><b>Existing Property</b></p> <p>The Contractor shall take every precaution to avoid damage to all if any, existing property including hard and soft landscaping, buildings and access routes. The Contractor will be held responsible for all damage thereto and shall make good all such damage when directed all at his own expense. The Contractor shall satisfy himself prior to commencing the work of the type, location and depth of all existing services and other works not visible and shall allow for providing all necessary protection required.</p> <p>Any damage or disturbance caused shall be reported immediately to the Engineer and made good at the Contractor's expense.</p> <p>Should it be found necessary to interrupt any service, prior approval of the method and timing must be obtained in writing from the Engineer.</p>	
B.	<p><b>Access to the site</b></p> <p>Means of access to the Site shall be agreed with the Engineer prior to commencement of the work.</p>	
C.	<p><b>Hoarding</b></p> <p>Where necessary, as identified by the Engineer the Contractor shall provide, maintain and clear away on completion hoarding required for the work areas, access ways and storage areas. The hoarding shall be 3m high G.C.I, or such other material as may be approved by the Engineer. Advertisements will not be permitted on the hoarding or any other part of the site.</p>	
D.	<p><b>Power and Water</b></p> <p>The Contractor shall be responsible for the provision of power and water supplies for use in the works. The contractor shall have satisfied himself as to the source and nature of these services and his tender shall be deemed to include for all such requirements and other matters necessary for the completion of the works.</p>	
	<b>Amount Carried to collection</b>	

<b>Item No.</b>	<b>General preliminaries (CON'T)</b>	<b><u>KShs</u></b>
A.	<p><b>Provisional works</b></p> <p>All works described as “Provisional “in these bills of quantities is subject to re-measurement in order to ascertain actual quantity executed for which payment will be made</p> <p>All “provisional” and other works liable to adjustment under this contract shall be left uncovered for a reasonable time to allow for all measurements needed for such adjustment to be taken by the Engineer. Immediately the work is ready for measuring, the contractor shall give notice in writing to the Engineer.</p> <p>If the contractor makes default, in these respects he shall if the Engineer so directs uncover at his expense the work to enable all measurements to be taken and afterwards reinstate at his own expense</p>	
B.	<p><b>Prevention of Nuisance</b></p> <p>The works and such sections of the site necessary therefore shall be under the entire care and control of the Contractor during the whole period of the Contract and he shall take all possible precautions to prevent any nuisance, inconvenience or injury to the holders or occupiers of the existing or surrounding properties and to the public generally and shall at all times keep all paths and roads affected by the Works in a safe and clear state, safety of all wheeled traffic and pedestrians.</p>	
C.	<p><b>Labor camps</b></p> <p>The employer shall not allow for erection or maintenance of labor camp on site “The Contractor shall therefore include in his prices for the transport of materials, workmen and plant to and from the site of the proposed works, at such hours and by such routes as are permitted by the Authorities</p>	
	<b>Amount Carried to collection</b>	

Item No	<b>General preliminaries (CON'T)</b>	<b><u>KShs</u></b>
A.	<p><b>Temporary buildings</b> The Contractor must provide for all temporary buildings required for the storage of materials and he must maintain them and clear them away on completion of the works to the satisfaction of the Engineer.</p>	
B.	<p><b>Contractor's superintendence/site agent</b>  The Contractor shall constantly keep on the works literate English speaking Agent or Representative, competent and experienced in the kind of work involved who shall give his whole experience in the kind of work involved and shall give his whole time to the superintendence of the works. Such Agent or Representative shall receive on behalf of the Contractor all directions and instructions from the Project Manager and such directions shall be deemed to have been given to the Contractor in accordance with the Conditions of Contract.</p>	
C.	<p><b>Copyright</b> The copyright of these documents is vested in the Project manager and they may not be reproduced in whole or in part without the Quantity surveyor's written permission.</p>	
	<b>Amount carried to collection</b>	

Item No	<p style="text-align: center;"><b>General preliminaries (CON'T)</b></p> <p style="text-align: center;"><b><u>Collection</u></b></p> <p style="text-align: center;">Page 75</p> <p style="text-align: center;">Page 76</p> <p style="text-align: center;">Page 77</p> <p style="text-align: center;">Page 78</p> <p style="text-align: center;">Page 79</p> <p style="text-align: center;">Page 80</p> <p style="text-align: center;">Page 81</p>	<b><u>KShs</u></b>
	<p><b>AMOUNT CARRIED TO GRAND SUMMARY- PG. 75 OF 81 OF THE BILLS OF QUANTITIES</b></p>	

**SECTION VI: BILLS OF QUANTITIES**

Item No.	Description	Unit	Quantity	Rate (Ksh)	Amount (Ksh.)
<b>A.</b>	<b>The following shall form costs for construction/installation ( Installation only) of 20Km Intermediate Wildlife Electric fence as per the drawings and specifications: <u>Clearing of vegetation; earthworks, cutting of drains, Pegging; Excavation of holes to receive posts; Construction of assemblies: single; double and corner assemblies; Ramming of posts; Tying of Strainers and reels; Fixing of W – Insulators; Straining of wires, Fixing of spring gates; Construction of energizer houses; Powering; Testing and Commissioning; Handing over</u></b>				
	<b>SITE CLEARANCE</b>				
A1.	Bush clearing 3m on either side of fence alignment and remove trees, hedges as directed by the engineer	Sum.	120,000		
Ali.	Cut trees, remove stumps (>400mm) and grub up roots	No.	1,000		
A2	Backfill in layers of 150mm and compact up to 100% MDD (AASHTO T99) with approved material as directed	c.m.	2,000		
	<b>EARTH WORKS</b>				
A3.	Fill in approved soft material in selected areas as directed	c.m.	5,000		
A4.	As item A2 for compaction of top 300mm in fills to	c.m.	5,000		

	100% MDD (ASHTO T99) in areas as directed				
	<b>Sub - Total b/f (A)</b>				
	<b>FENCE WORKS</b> <b>Note: The employer will provide the following materials apart from item A31 to A34 and item B1 Which the contractor will provide.</b>				
A7.	Line Posts	Pc	2,200		
A8.	Strainer Posts	Pc	1,000		
A9.	2.5mm High Tensile Wire (HTS)	Roll	280		
A10.	4.0mm Soft wire	L.M.	5,000		
A11	Barbed Wire	Roll	10		
A13.	2" Staple U - Nails	Kg	600		
A14	5" Straight Nails	Kg.	600		
A16.	Earth Pegs	Pc	120		
A17.	Warning signs	Pc	210		
A18.	W-Insulators.	No.	15,000		
A19.	Strain End insulator	No.	1,500		
A20.	Joint Clamps	Pc	1,500		
A21.	Reel Insulator	No.	1500		

A23.	Energizer 16 Joules stored Energy (Solar) – option 2	Pc	3		
A24.	140W Solar Panel	Pc	3		
A25.	100 Ah Solar battery	Pc	3		
A26.	Charge regulator	Pc	3		
A27.	2.5mm dia. Under gate cable	Roll	3		
A28.	Flood gate controller	Pc	6		
A29.	Lightening Diverters/Arrestors	Pc	3		
A30.	Spring gate	Pc	12		
A31	Single strainers	Pc	3		
A32	Maun cutting Pliers	Pc	3		
A33	Wire dispenser	Pc	2		
A34	Digital Voltmeters	Pc	5		
<b>B.</b>	<b>CONSTRUCTION OF ENERGIZER HOUSES</b>				
B1	Allow for construction of energizer unihuts as per attached manufacturer's installation catalogue	No.	9		
	<i>Sub – Total b/f (B)</i>				
	<b>Total carried to Grand Summary – (A) + (B)</b>				

Item No.	Description	Amount Kshs.
	<p style="text-align: center;"><b><u>KENYA WILDLIFE SERVICE</u></b>  <b><u>PROPOSED CONSTRUCTION &amp; MAINTENANCE OF</u></b>  <b><u>THE PROPOSED 20KM WILDLIFE ELECTRIC</u></b>  <b><u>FENCE IN MERU N. PARK- (LABOUR CONTRACT)</u></b></p> <p><b>GRAND SUMMARY</b>  <b>From Page</b></p>	
A.	Preliminaries.	
B.	Bill of Quantities.	
	<b><i>Sub - Total</i></b>	
	Add 5% for Contingencies	
	<b>GRAND TOTAL CARRIED TO FORM OF TENDER</b>	



**SECTION VII: PERFORMANCE BASED MAINTENANCE  
CONTRACT (PBC)**

**PART 1: IMPORTANT NOTICE TO TENDERERS ..... 87-92**

**PART 2: CONDITIONS OF CONTRACTS.....92**

**GENERAL CONDITIONS OF CONTRACT (GCC)**

**PARTICULAR CONDITIONS OF CONTRACT (PCC)**

**STANDARD CONTRACT FORMS**

**Form of Agreement**

**Form of Performance Bank Guarantee**

**PART 3: SPECIFICATIONS .....93 -04**

**GENERAL SPECIFICATIONS**

**PERFORMANCE SPECIFICATIONS**

**BILL OF QUANTITIES**

## **PART 1: IMPORTANT NOTICE TO TENDERS**

- 1) This is a hybrid Tendering Document and has been prepared for the Procurement of Works under Performance Based and Unit Rate Based Wildlife Electric Fence Maintenance type of Contract. The contract covers an array of activities needed to achieve and maintain a functional fence, including many activities related to the **Management and Maintenance** (including Routine maintenance, spot improvement, emergency works and Periodic Maintenance) of the electric fence under contract.
- 2) This Standard Tender Document (STD) for Procurement of Wildlife Electric Fence Maintenance Works under Performance Based Term Contract has been prepared for use by Procurement Entities in Kenya in the procurement of fence maintenance works. Exclusive preference shall be given to citizen contractors using open tendering methods where the amounts are below the threshold set out in the Public Procurement and Disposal Act, 2015 and its attendant Regulations. Otherwise, any tender shall be through International Competitive Tendering (ICB) and National Competitive Tendering (NCB) procedures without discrimination.
- 3) In the Performance Based Contract (PBC), contractors compete among each other during the tendering process, by essentially proposing fixed lump-sum prices for bringing the electric fence to required conditional and functional level and then maintaining it at that level for a specified period. Payments made to the contractors are not based on quantities of works measured by unit prices for works “inputs” or physical works, but on measured ‘outputs’ reflecting the specified and target conditions of the fence under contract. This is expressed through ‘**Conditional** (*structurally sound in all aspects, service road and fire break well maintained and no overgrowth of vegetation along fence line*) **and Functional** (*min. voltage reading at 5KV*) **Levels**’, i.e., the Rehabilitation of the fence to pre-defined conditions (as required by the tendering documents in relation to material specifications), the maintenance service of ensuring specific functional Levels on the fence under contract, and specific improvements (as required by the tendering documents). All this represents outputs or outcomes. A monthly lump-sum remuneration paid to the Contractor will cover all physical and non-physical

maintenance services provided by the Contractor, except for unforeseen emergency works which are remunerated separately as opposed to traditional fence construction and maintenance contracts, where the Contractor is responsible for the execution of works which are normally defined by the Employer. The Contractor is paid on the basis of unit prices for different quantities of measured work items, i.e., a contract based on “inputs” to the works.

For example, the contractor is not paid for say, 50m long by 5m width fire break along fence line cleared of vegetation growth (his actual work input) in a certain month, but for ensuring there is no vegetation growth within the fire break at all times (the output of his efforts). This means that in some months the Contractor will be paid the agreed standard monthly lump sum amount even though much work has not been done. In other words, it is possible that during some months, the contractor will have to carry out a rather large amount of physical works in order to comply with the required conditional and functional Levels and very little work during other months.

The agreed monthly payment for maintenance works and services will be made to the Contractor if he has complied, during the month for which the payment is to be made, with the agreed Conditional and Functional Levels on the Electric Fence under contract. Together with his monthly invoice, the Contractor will report the result of his own evaluation of compliance with the required Conditional and Functional Levels, based on his own monitoring system which is mandatory. His statement will then be verified by the Employer or his representative (supervisor) through joint inspection with an Engineer or appointed representative. If the Conditional and Functional Levels are not met, payments are reduced, based on a schedule given in the contract. Payments may even be suspended, and the contract cancelled, if the contractor fails during an extended period to achieve specified minimum threshold values of Conditional and Functional Levels. **This component of contract describes the formulas used to calculate payment reduction and potential contract suspensions.**

- 4) The unit rate-based term contract on the hand include:
  - a) Carrying out **Rehabilitation Works** to bring the Electric Fence up to pre-defined conditions.
  - b) **Improvement/upgrading Works** specified by the Employer aiming at adding new characteristics to the Electric Fence in response to new translocated wildlife, safety or other conditions.
  - c) **Emergency Works** needed to reinstate the Electric Fence after damage has occurred as a result of natural phenomena with imponderable consequences under the conditions defined in the contract.

- d) The Rehabilitation and Improvement Works where explicitly specified by the Employer in the contract are quoted on the basis of measurable output quantities and paid as performed. In order to be entitled to the monthly payment for maintenance services, the Contractor must ensure that the Electric Fence under contract comply with the Conditional and Functional Levels which have been specified in the tendering document.
- 5) When improvement, rehabilitation or emergency works are required, a well-designed bill of quantities defining specific outputs for tenderers to price and, later on, allow measurement and payment of the Contractor is provided. Emergency works, although impossible to quantify in advance, will occasionally be necessary. To allow tenderers to offer prices for Emergency Works, a unit price bill of quantities (similar for civil works under unit prices) / shall be prepared for tenderers to price for tender evaluation purposes. Later on, these unit prices and real measured volumes of Emergency Works executed will be used for payments.
- 6) Another major difference is that the Contractor is responsible for deciding on the works necessary to reach the required Conditional and Functional Levels, and the durability and performance of the Electric Fence over a longer period. Although the design of the Rehabilitation, Improvement or Emergency works to be carried out is under the responsibility of the Employer, a good preparatory engineering work is required to be prepared by the Contractor for the design produced by him and programming of the Works and Maintenance services. It is necessary to prepare comprehensive information on the actual condition of the Electric Fence covered by the contract.
- 7) Minimum Electric Fence Conditions and Functional Levels are defined through Conditional and Functional levels and, and these are used under the PBC to define and measure the desired performance of the Contractor. In the PBC, the defined performance measures are thus the accepted minimum thresholds for the Condition and Functional levels of the Electric Fence for which the Contractor is responsible.
- 8) The performance criteria will cover all aspects of the contract and take account of the fact that different sub-areas within the contract area might require different measures of Conditional and Functional Levels. Criteria has been defined at two different categories:
- (a) **Functional** measures,
  - (b) **Fence Durability** measures,
- 9) A fundamental feature of the PBC is that any type of firm or business venture having the necessary technical, managerial and financial capacity to fulfil the contract is eligible and not necessarily the traditional works contractor. However, for this contract, the contractor awarded construction of new works shall proceed to maintain the fence over a specified

period and as stipulated in the Conditions of Contract, the contractor is responsible for designing and carrying out the works, services and actions he believes are necessary in order to achieve and maintain both conditional and functional Levels stated in the contract. The Levels are defined based on the ability of the fence to offer deterrence to any intrusion by the public or wildlife. If the said Levels are not achieved in any given month, the payment for that month may be reduced or even suspended.

- 10) Under the Performance based Contract (PBC), the Contractor has a strong financial incentive to be both efficient and effective whenever he undertakes work. In order to maximize profits, he is able to reduce his activities to the smallest possible volume of intelligently designed interventions, which nevertheless ensure that pre-defined indicators of Service Level are achieved and maintained over time. This type of contract makes it necessary for the Contractor to have a good management capacity. Here, “management” means the capability to define, optimize and carry out on a timely basis the physical interventions which are needed in the short, medium and long term. This is done in order to guarantee that the electric fence remain above the agreed Levels. In other words, within the contract limitations and those required to comply with local legislation, technical and performance specifications and environmental and social regulations, the Contractor is entitled to independently define: (I) what to do, (ii) where to do it, (iii) how to do it, and (iv) when to do it. The role of the Project Manager on behalf of the Employer is to enforce the contract by verifying compliance with the agreed Levels and with all applicable legislation and regulations.
  
- 11) Maintenance of wildlife electric fence includes both **routine** and **periodic** tasks. Routine maintenance consists of many different tasks frequently necessary to maintain the function of the fence (such as control of vegetation growth along fence line, cleaning of drainage, ensuring ‘Hatari’ signs are in place, etc.). Periodic maintenance consists of predictable and more costly measures of a less frequent nature designed to avoid fence degradation (such as replacement and tensioning of HTS wires or mesh, replacement of any termite infested or cracked line, strainer posts and corner assemblies, grading of service road where necessary, drainage work, resurfacing, etc.). Intelligent management, the timeliness of interventions and the adequacy of technical solutions are critical.  
When Rehabilitation Works and Improvement Works are not specifically required in the tendering documents, it is expected that in order to comply with the contract, the Contractor will most likely have to carry out different types of works, including some small initial rehabilitation and improvements, routine maintenance activities and periodic maintenance works. The definition of the exact nature of the works, their timing, their costing and their implementation is left to the judgment of the Contractor. This means that his capacity must be above the usual capacity of a traditional

civil works contractor. In fact, an essential attribute is the capacity to manage electric fence, while the actual physical execution may either be carried out by the Contractor himself, or by different specialized firms participating in a Joint Venture with the main contractor, or under subcontracts. Joint Ventures may include Engineering firms and medium, small and even micro-enterprises.

Tenderers will present their financial offer as appropriate for:

- the Performance Based **Maintenance Services** in the form of the amount of the monthly lump-sum payment demanded by the tenderer according to the conditions of contract (this will be a monthly amount applicable throughout the duration of the contract);
  - the **Rehabilitation Works** (if so, required in the Instructions to Bidders), in the form of a lump-sum amount, while indicating the quantities of measurable outputs to be executed in order that the electric fence achieves the performance standards specified in the tendering documents. Payments will be made in accordance with the progress in the execution of those measured outputs;
  - the **Improvement Works** (if so required and for the improvements indicated in the tendering documents) in the form of unit prices for outputs of each type of improvement works; payments for improvements will be made in accordance with quoted unit prices for those outputs; and
  - Unit prices for **Emergency Works** in the form of a traditional bill of quantities. Payments will be made for each emergency on a case-by-case basis, in the amount of a lump-sum value estimated by the Contractor and approved by the Employer, on the basis of the estimated quantities and on the quoted unit process.
- 12) Another important aspect in the Performance type of contract is for the contractor and Employer to enter into a long-term relationship whereby the contractor takes over more responsibility for managing the condition of the Electric fence and is rewarded by a longer-term contract than is traditional; sometimes several years.
- 13) In case of any conflict between the provisions outlined in this standard tender document and The Public Procurement and Disposal Act, 2015 and its attendant Regulations 2006, the latter shall prevail.

## **PART 2: GENERAL CONDITIONS OF CONTRACT (PCC)**

The General Conditions Part I and Conditions for Particular Applications Part II shall apply.

### **PART 3: PARTICULAR CONDITIONS OF CONTRACT (PCC)**

The following Particular Conditions shall supplement the Conditions of Contract. They are to be completed by the Employer and presented as part of the Tendering Documents. Whenever there is a conflict, the provisions herein shall prevail over those in the GCC.

#### **Reference to GCC clauses where applicable**

	<p>The Project Location <b>is Meru N. Park</b>, the electric Fence shall be from ----- to----- and <b>is approximately 20 KM/</b></p> <p>The name of the Engineer is -----</p>
	<p>The following documents are also part of the Contract: <b>(Standard specifications for Roads and Bridges Constructions, Road Design Manual Part I and II)</b></p>
	<p>The language of the Contract shall be <b>English</b>.</p> <p>The law of the Contract is that of <b>the Republic of Kenya</b>.</p>
	<p>The address of the Employer is: <b>[Director General, Kenya Wildlife Service P.O. Box 40241 – 00100, Nairobi.</b></p> <p><b>Tel -----</b></p> <p><b>Email: <a href="mailto:info@kws.go.ke">info@kws.go.ke</a>.</b></p>
	<p>The contractor shall be responsible for the IMMEDIATE maintenance of the fence to the required Performance standards during the period of construction. The Start Date for maintenance (PBC) shall be <b>IMMEDIATELY</b> after declaration of practical completion of all Works and shall run concurrently with Defects Liability Period (DLP), which shall terminate after Six (6) Months. The PBC shall run for <b>Twenty-Four (24) Calendar Months</b> upon issuance of <b>Order to Commence</b>.</p>

	The Time for completion of Construction Works shall be 9 Months
	The Contractor is specifically allowed to sub-contract the following activities: <b>[N/A]</b>
	The Employer shall give full possession of and access to the Site as specified in the letter of commencement.
	The Program of Works is also referred to as the Works Execution Programme. The Contractor shall submit the cash flow projections together with the work programme. Times of completion given in the Time Schedule in PCC Clause 4.2.
	The key personnel shall consist of: <b>Project Manager, Site Agent, Electrical Superintendent and Foreman</b> <i>[The Employer shall specify any additional personnel required]</i>  The key staff listed above must have academic qualifications from government recognized or equivalent institutions as specified in the Qualification Criteria. The Qualifications shall be subject to verification and approval on site by the Engineer or his representative on site before commencement of work. Any replacement of the above personnel should be approved by the Employer.
	The contractor SHALL engage <b>UNSKILLED</b> labour from the local communities neighbouring the fence line
	The scope of the occupational health and safety programme shall include <b>any other rules and regulations as may be issued</b>
	The Contractor shall carry out the following Rehabilitation Works, which are detailed in the Specifications: <b>[As set out in the scope of works of the BOQ]</b>
	The Contractor shall carry out the following Improvement Works, which are detailed in the Specifications and Bill of Quantities: <b>[N/A]</b>
	Maintenance service will be measured not only by compliance with the Performance Specifications but also with Contractor's performance of work process during the contract according to <i>Performance Based Road Maintenance Contract Guideline, 2016</i> . The contractor's Evaluation result will be represented by score and referred at subsequent procurement.
	The Contractor shall establish a Self-Control Unit with the following minimum requirements <i>[insert minimum requirements]</i> <b>[, the minimum requirement shall be the Electrical Superintendent or Site Agent, Forman, Labourers</b>



***and a pick up for daily inspection.]***

20.4

Further to Clause 32.1 and 33.1, schedule of allocated risks are as follows;

<b>Risk Item</b>	<b>Rehabilitation Contracts</b>		<b>PBC Contracts</b>	
	<b>Public Sector</b>	<b>Contra ctor</b>	<b>Public Sector</b>	<b>Contra ctor</b>
Design Risk	√			√
Construction Risk		√		√
Technical & Management Risk	√			√
Performance Risk	√			√
Political Risk	√		√	
Social & Environmental Risk	√		√	√
Acts of God and Force Majeure Risk	√	√	√	√

The Contractor shall report to the Engineer details of any accident within 24 hours of its occurrence. In the case of any fatality or serious accident, the Contractor shall, in addition, notify the Engineer immediately by the quickest available means. The Contractor shall also notify the relevant authority whenever the Laws of Kenya require such a report.

The Contractor shall take out and maintain in effect the following insurances in the sums and deductibles shown below: *[Contractors All risk insurance]*

	<p>The Time for Completion are the following:  Rehabilitation works is <b>3months, where applicable</b>  PBC maintenance is <b>24 months</b></p>
	<p>For <b>Rehabilitation Works</b>, the liquidated damages are 0.2% per calendar day of delay, of the payment normally due for the specific Works for which completion is delayed.  For <b>Improvement Works</b>, the liquidated damages are <i>[Not Applicable]</i> per calendar day of delay, of the payment normally due for the specific Works for which completion is delayed</p>
	<p>The limit of liquidated damages is <i>[insert <b>fixed amount</b>, or <b>percentage of contract amount</b>]</i></p>
	<p>The defects liability period for rehabilitation and improvement works shall be <i>[1 month]</i></p>
	<p>The payment of the Contract Price will be made in the following currencies: <i>Kenya Shillings (KES)</i></p>
	<p>The amount of the Advance Payment is <i>[N/A] <b>Price</b> as specified in the Form of Contract]</i>  The Advance payment will be made by <i>[Not Applicable]</i></p>
	<p>The Advance payment will be repaid during the <i>N/A]</i> initial monthly payments at the rate of <i>N/A]</i> per cent of the amount advanced in each monthly payment until the repayment of the total amount.</p>
	<p>In case there is no Applicable unit rate for an Emergency Activity in the contract, the prevailing market rates shall be used as agreed between the contractor and the Employer,</p>
	<p>In accordance with the Conditions Sub- Clause 56.1, the Contractor shall submit the estimated values of the Works and Maintenance Services executed or performed during the month as the Contractor's Monthly Statement to the Engineer. The Monthly Statement shall clearly indicate the Works executed in the form of the approved Bill of Quantities of the Rehabilitation Works, the Improvement Work and the Emergency Works, as fit for the month. The Monthly Statement shall also clearly indicate the fixed value of the Maintenance Services performed in the form of the approved Bill of Quantities, less any reductions to be made during the particular month based on the Payment Reduction Calculation Table calculated by the Contractor to determine the percentages of non-compliance for each Scope for determining the amount of reduction.</p>
	<p>Rehabilitation Works will be measured on the basis of <i>[work outputs]</i></p>
	<p>Improvement Works will be measured on the following basis: <i>[N/A]</i></p>

	The minimum amount of Interim Payment Certificate is Ksh. 200,000.00
	The retention for Rehabilitation Works is fixed at <b>10%</b> per cent. The retention is not applicable to the following types of Rehabilitation Works: <b>[N/A]</b>
	The amount of the Advance payment security is <b>[N/A]</b>
	The amount of the Performance Security is <b>[10% of Rehabilitation component]</b> .
	The form of guarantee is <i>[Unconditional Bank guarantee]</i> .
	The condition of persistent failure to execute the contract is given if and when the total amount of payment reductions and liquidated damages applied under the contract reaches <b>[10%]</b> per cent of the total contract amount.
	The Employer has the right to propose a change in the contract: Yes or No <b>[Yes]</b> .

#### **PART 4: SPECIFICATIONS FOR PBC**

##### **Introduction to Specifications**

##### **(A) General Specifications**

Notwithstanding the provisions of Clause 7 of the GCC, the Works and Maintenance Services to be provided by the Contractor include all activities, physical or others, which the Contractor needs to carry out, in order to comply with the service levels and other performance criteria indicated under the contract, or with any other requirements of the contract. In particular, they include management tasks and physical works in accordance with the latest standards and designs guidance issued by the Ministry responsible for Roads in Kenya as may be revised from time to time including and not limited to;

- a. Standard Specification for Roads and Bridge Construction, Ministry of Transport and Communications of the 1986 except as supplemented, modified or revised in the Special Specifications and Performance Specifications.

##### **(B) Detailed Specifications**

Detailed specifications are contained in the contract for construction of Wildlife Electric Fences.

##### **(C) Performance Specifications**

The Maintenance Works or services to be provided by the Contractor include all activities, physical or others, which the Contractor needs to carry out, in order to comply with the service levels and other performance criteria indicated in the Performance Specifications under the contract, or with any other requirements of the contract.

**(D) Special Specifications**

Special specification is supplementary to the Standard Specifications and the two must be read in conjunction. In any case where there appears to be conflict between the two, then the Special Specifications will take precedence.

## **A. GENERAL SPECIFICATIONS**

The contractor must familiarize himself with the General specifications for Road works as contained in.

### **Standard Specification for Road and Bridge Construction**

Published by the Ministry of Transport and Communications of the Republic of Kenya, 1986.

Work shall be carried out in accordance with the Standard Specification except as supplemented, modified or revised in the Special Specification.

## **B. DETAILED SPECIFICATIONS**

The contractor must familiarize himself with the Detailed Specifications as contained in the contract for construction of Wildlife Electric Fences.

## **C. PERFORMANCE SPECIFICATIONS**

For purposes of this PBC contract, performance specifications shall be considered as the general condition and Functional capabilities

### **1.1. Condition and Functional Criteria**

The following condition Criteria for the Electric Fence shall apply:

- i. Structural soundness/integrity
- ii. Vegetation growth
- iii. Condition of Service Road
- iv. Condition of Fire break, and

for Functional Criteria:

- v. Fence Voltage Reading

## **2. Works and Services to be provided**

### **2.1. Works**

The Works are what the Contract requires the Contractor to construct, install, and turn over to the Employer, as covered under Rehabilitation Works, Improvement Works and Emergency Works.

### **2.1.1. Rehabilitation Works**

Rehabilitation Works are a set of measurable inputs to be executed by the Contractor during the Initial Mobilization Period to allow the Electric fence to achieve the performance standards required under the contract. Rehabilitation Works shall be carried out by the Contractor in accordance with the Bill of Quantities. Rehabilitation Works will be paid for as measured items in accordance with the unit rates in the Bill of Quantities.

### **2.1.2. Improvement Works**

Improvement Works are a set of interventions to be executed by the Contractor to allow the Electric Fence to acquire new characteristics under the contract. Improvement Works shall be carried out by the Contractor when specifically instructed by the Engineer in accordance with the conditions of contract and with the Bill of Quantities. Improvement Works will be paid for as measured items in accordance with the unit rates in the Bill of Quantities.

### **2.1.3. Emergency Works**

Emergency Works are a set of necessary inputs to be executed by the Contractor to allow the Electric Fence to be reinstated under the contract in case of inflicted damages as a result of natural phenomena with imponderable consequences, such as strong storms, flooding and earthquakes. Emergency Works shall be carried out by the Contractor when specifically instructed by the Engineer as set out in the conditions of contract and in accordance with the unit rates provided for in the Specifications.

In the event of an emergency, the Contractor shall draw to the attention of the Engineer that certain works need to be carried out to reinstate the Electric Fence and other features to restore its ability to deter possible intrusions.

The Engineer who will determine the quantities of activities to reinstate the Electric Fence, shall make the payments according to the measured works.

### **2.1.4. Design Responsibility for Works**

All Works, Rehabilitation Works, Improvement Works and Emergency Works shall be designed by the Employer in accordance with the latest specifications adopted by the Employer.

## **2.2. Maintenance Services**

Maintenance Services to be provided by the Contractor include all activities, physical and others, which the Contractor needs to carry out in order that specific Electric fence related assets and items comply with the Fence Performance Standards as defined by the condition and functional Levels and other output and performance criteria indicated in the contract, or with any other requirements of the contract. In particular, they include management tasks and physical works associated with the following Electric Fence related assets and items:

[Note: List the extent of specific Electric Fence related assets and items that are to be maintained under the contract. The list of assets and items may include:

- 1) Line posts
- 2) Strainer posts
- 3) Corner assemblies
- 4) HTS wires
- 5) Soft Wires
- 6) Mesh wires
- 7) Plain wires
- 8) Line Insulators
- 9) Line, Strain End and Corner insulators
- 10) Energizers
- 11) Solar Panel
- 12) Charge Controller
- 13) Lightning Diverter/Arrestor
- 14) Gates
- 15) Earth peg
- 16) Hatari/Warning/Danger sign
- 17) Spring Gates
- 18) Joint Clamp
- 19) Under gate cables
- 20) Service road
- 21) Fire break
- 22) Drainages

**Maintenance service delivery outputs**

During the entire PBC contract period, the Contractor is expected to achieve the following outcomes:

1. No weak structural line, corner assemblies and strainer posts
2. No inclined posts
3. No slacks in wires and mesh
4. The min. voltage reading is 5KV
5. No vegetation growth along fence line
6. No clogging of drainages
7. No standing water along the fence line

8. The access road remains passable
9. The fire break is free of vegetation growth

For guidance, the activities to be undertaken by the Contractor include, but are not limited to, management tasks and physical works associated with the following:

1. Inspect the electric fence for defects likely to impact on durability of the fence assets
2. Check tension of wires
3. Check the voltage readings along the entire fence line
4. Inspect the energizers for any indication of short circuiting
5. Inspect fence, identify and remove all obstructions
6. Clean drainages of debris
7. Repair weak line posts, corner assemblies and strainer posts
8. Control vegetation by cutting grass, bush clearing and tree pruning
9. Repair any cut wires and mesh, and tension accordingly

The Contractor shall prepare and submit Routine Maintenance strategy for approval by Engineer.

Maintenance Services shall be paid for as a fixed **lump sum per km per month, with payment reductions made for non-compliance**, if appropriate.

### **3. Programme of Performance**

In accordance with clause 14.1 of the General Conditions of Contract (GCC), the Contractor shall submit a Program of Performance within twenty-eight (28) days after the signing the contract agreement. The program shall include, but not be limited, to the following items:

#### **3.1. Contractor's Quality Assurance Plan**

The purpose of the Contractor's Quality Assurance Plan is to integrate the requirements of the contract and the Contractor's quality assurance systems to deliver the Works and Services.

The Contractor's Quality Assurance Plan describes the methods and procedures which the Contractor will apply for the execution of the Contract, including how the Contractor will:

- (a) Identify the quality requirements specific to the contract,
- (b) Plan and execute the Works and Services to satisfy those requirements
- (c) Inspect and/or test the Works and Services to ensure compliance with the quality requirements



- (d) Record and monitor the results as evidence of compliance, and
- (e) Ensure that prompt action is taken to correct non-compliance.

The Contractor's Quality Assurance Plan must clearly describe the systems, procedures and methods that will be used to deliver and monitor compliance of the Works and Services.

### **3.2. Safety Management Plan**

If required in the Particular Conditions of Contract (PCC) the Program of Performance shall include a Safety Management Plan. The Safety Management Plan establishes the practices for safety management at work sites. The Safety Management Plan must be developed by the Contractor and agreed with the Engineer.

The objectives of the Safety Management Plan are to:

- (a) Clearly define and document the responsibilities and chain of command for the development, implementation and management of safety control measures and systems
- (b) Establish the minimum requirements for the safety of workers, road users and community people using the Road
- (c) Protect the Contractor's personnel at all times

The Safety Management Plan must include at least the following:

- Method statements for implementation of work safety undertaking on each aspect of the Works and Services (including safety gears for workers, use of tool box meetings for safety awareness, provision of work safety signs, training of workers on safe use of tools and equipment, safety inspection under the patrolling by Self Control Unit and commitment by the Contractor on adherence to the Occupational Safety and Health Act, 2007 amended on 2010.)
- A documented process for preparation, review and approval of the Safety Management Plan
- A document tracking and control system to ensure that only the latest operative copy of the Safety Management Plan is in circulation
- Contact details for Contractor, Engineer, emergency services and other stakeholders

### **3.3. Environmental Management Plan**

If required in the Particular Conditions of Contract (PCC) the Program of Performance shall include an Environmental Management Plan. The Environmental Management Plan establishes the practices for environmental management at work sites. The Environmental Management Plan must be developed by the Contractor and agreed with the Engineer.

The objectives of the Environmental Management Plan are to:

- (a) Clearly define and document the responsibilities and chain of command for the development, implementation and management of environmental control measures and systems
- (b) Establish the minimum requirements for environmental control measures for maintaining the adequate environment for workers, road users and community people using the Road
- (c) Maintain the awareness of the Contractor's personnel on environmental protection at all times

The Environmental Management Plan must include at least the following:

- Method statements for maintaining the adequate environmental on work sites undertaking on each aspect of the Works and Services (including specific dumping locations of debris and materials unwanted from the Road, use of tool box meetings for environmental protection awareness, training of workers on environmental control measures, inspection under the patrolling by Self Control Unit and commitment by the Contractor on adherence to the regulations and acts enacted by the government of Kenya under National Environmental Management Authority.)
- A documented process for preparation, review and approval of the Environmental Management Plan
- A document tracking and control system to ensure that only the latest operative copy of the Environmental Management Plan is in circulation
- Contact details for Contractor, Engineer, emergency services and other stakeholders

#### **3.4. Emergency Procedures and Contingency Plan**

If required in the Particular Conditions of Contract (PCC) the Program of Performance shall include an Emergency Procedures and Contingency Plan which shall establish the roles, practices and procedures during specific types of emergency events identified in the plans and contingency plans associated with the closure of roads. The Emergency Procedures and Contingency Plan must be developed by the Contractor and agreed with the Engineer and any other stakeholders the Engineer may identify.

The purpose of the Emergency Procedures and Contingency Plan is to ensure the safety of the Contractor's personnel and road users in the case of emergency and/or road closure. It should include:

- an effective communication and event recording system
- the name, contact number and specific duties of the Contractor's personnel nominated to respond to an emergency event

- the contact number of other parties who need to be notified in cases of emergency events, e.g., police
- detailed response procedures for all emergency events
- possible detour routes in the event of road closure

#### **4. Condition and Functional Level Criteria**

The Contractor is required to carry out the Maintenance Services and to maintain the specific Electric Fence related assets and items during the contract duration in compliance with the Fence Performance Standards as defined by the Service Criteria as stipulated hereunder.

The Employer requires the Contractor to maintain the Electric Fence under the contract to remain in sound structural state and functional with ability to offer barrier to any intruder including wildlife and the public. In order that the Contractor can achieve such, criteria for condition and functional levels must be adhered to as below

- 1) **Conditional levels** – the fence is structurally sound in all aspects, no overgrowth of vegetation along fence line, fire breaks cleared of any vegetation growth, and service road well maintained, motorable and drainages cleared of any debris.
- 2) **Functional levels** – the minimum voltage reading along the fence line is **5KV**. The security management system remains functional and the central command room receives real time monitoring information.

#### **5. Self-Control Unit (SCU)**

The Contractor is required to establish a Self-Control Unit within his project organization throughout execution and completion of the Works and Services to the satisfaction of the Engineer. The roles of the SCU:

1. For conducting self-inspection to verify the degree of compliance with the Electric Fence Performance Standards as defined by the Service Levels and maintain the reporting system of self-inspection.
2. Assessment of the Electric fence. The Self-Control Unit shall have a complete knowledge of the road condition, both on and off carriageway, at all times by carrying out patrolling, to the satisfaction of the Engineer.
3. The Self-Control Unit is responsible for Gathering information required by the Contractor to prepare the Monthly Statement.
4. The carrying out, in close cooperation with the Engineer, the Formal and Informal Inspections of condition and functional levels which will take place as required.

The Contractor is required to assign a technically qualified and trained person, or persons, to continuously verify the degree of compliance of condition and functional Levels. The Contractor is also required to arrange a satisfactory means of mobility for conducting inspections to the satisfaction of the Engineer.

## **6. Site Inspection and Reporting**

The Contractor is required to undertake the following management tasks to ensure the full integrity of the Electric Fence throughout execution and performance of the Works and Maintenance Services.

### **6.1. Site Condition Assessment before Commencement of Works and Services**

The Contractor shall conduct initial site condition assessment before commencement of the Works and Services under the contract. In case any defects and deficiencies are discovered under the assessment, the Contractor shall notify the Engineer by submitting the Defect Detection and Rectification List as attached to the **Appendix 4** of the Performance Specifications and upon agreement of the Engineer, the Contractor shall carry out rectification works as the Rehabilitation Works.

In case the Contractor discovers cases of illegal encroachment and illegal dumping of unwanted materials or otherwise illegal actions by the third parties, the Contractor shall notify the Engineer for further instructions as required.

### **6.2. Ad hoc Inspection**

The Engineer may carry out ad-hoc inspections to verify the degree of compliance with the Electric Fence Performance Standards as defined by the condition and functional Levels. He may do so on his own initiative, at anytime and anywhere on the fence under the contract. If he detects any stretches where the both the condition and functional levels are not met, he is required to notify the Contractor within 24 hours in writing as the Corrective Order, to enable the Contractor to take remedial action as soon as possible. The results of ad-hoc inspections may not be used by the Engineer for purposes of correcting the Contractor's monthly statements or applying penalties, except for cases in which the voltage readings has been completely interrupted due to the negligence and tardy action by the Contractor.

## **7. Monthly Statement**

### **7.1. Preparation for Monthly Statement**

For the Works and Maintenance Services executed and performed during the month, the Monthly Statement shall be prepared by the Contractor with the format of Monthly Statement as attached (**Appendix 7**).

For the Maintenance Services, the Contractor shall take the following actions;

- 1) Prior to compilation of the Monthly Statement for each month, the Contractor is required to prepare the Payment Reduction Calculation Table for the month by utilizing the result of the most recent self-inspection recorded in Self

Inspection Result Record Form to determine the total length of non-compliant sections for each Service Scope and for calculation of the reductions required for the month by determining the percentages of non-compliant sections for each Service Scope. The format of Payment Reduction Calculation Table is attached as **Appendix 9**.

- 2) The prepared Payment Reduction Calculation Table shall become the basis of the payment request for the Maintenance Services.
- 3) Upon completion of Formal Inspection, the amounts indicated on the Monthly Statement and the Payment Reduction Calculation Table will be adjusted, if required. Such modified Monthly Statement and Payment Reduction Calculation Table shall be countersigned by the Engineer to sign it and present it to the Employer for payment, and to the Contractor for information.

**7.2. Reduction Weighting for Non-Compliance on Maintenance Services**

In accordance with the relevant clauses of the Performance Specifications and GCC, payment reduction is applied in case of non-compliance with Service Levels.

The total aggregate weighting of 200% is applied to various Condition and Functional Criteria and Documentation. The reduction weighting for each is indicated below.

<b>Documentation</b>	<b>Reduction Weight in case of Non-Compliance</b>
1. Documentation (Submission of documents specified under Programme of Performance) (% doc)	<b>4%</b> of the monthly lump sum for one km applied if the document is not submitted.
2. Structural Soundness: (% ss)	<b>40%</b> of the monthly lump sum for one km applied to each one km section which does not comply.
3. Voltage Reading: (%vr)	<b>40%</b> of the monthly lump sum for one km applied to each one km section

		which does not comply.
3.	Maintenance of Service Road and Fire Breaks: (% sst)	<b>20%</b> of the monthly lump sum for one km applied to each one km section which does not comply.
4.	Visibility of Hatari Signs: (% hs)	<b>20%</b> of the monthly lump sum for one km applied to each one km section which does not comply
5.	Drainage Capability: (% dc)	<b>22%</b> of the monthly lump sum for one km applied to each one km section which does not comply
6.	Vegetation Control: (% vc)	<b>24%</b> of the monthly lump sum for one km applied to each one km section which does not comply
7.	Maintenance Security Management System: (% sms)	<b>30%</b> of the monthly lump sum for one km applied to each one km section which does not comply

(% xx indicates the percentage of either Condition or Functional level criteria for non-compliance during the month for criteria xx.

The amount of reduction for the Maintenance Services will be calculated as follows:

$$\% \text{Total} = (0.04 \times \% \text{doc}) + (0.40 \times \% \text{ss}) + (0.4 \times \% \text{vr}) + (0.2 \times \% \text{sst}) + (0.2 \times \% \text{hs}) + (0.22 \times \% \text{dc}) + (0.24 \times \% \text{vc}) + (0.3 \times \% \text{sms})$$

If the Contractor fails to remedy a cause of non-compliance for which a payment reduction has already been applied, the amount of the payment reduction increases month by month for that cause of non-compliance, without a ceiling being applied, until compliance is established. The amount of payment reduction for such case will be calculated as follows;

- 1) If the non-compliance has not been remedied within the first thirty days of non-compliance, additional payment reduction for periods beyond 30 days will be split into each 30 day.

2) The additional payment reduction for periods beyond 30 days is calculated using the formula indicated below,

$$PR = 2^n PR_0, \text{ where}$$

$$n = \left\{ \frac{J - 1}{30} \right\} \text{ rounded up to full number (without decimals)}$$

J = number of days of non-compliance beyond thirty days

PR<sub>0</sub> is the amount of the initial payment reduction.

## 8. Formal Inspection

The Formal Inspection shall be carried out jointly by the Engineer at the end of each month. The Engineer shall notify the Contractor that he intends to carry out Formal Inspection in writing within 7 days of notification. The Contractor shall inform the Engineer of the proposed date and time and shall prepare for Formal Inspection. The main purpose of carrying out the Formal Inspection is to enable the Engineer to verify the information presented in the Contractor's Monthly Statement with the actual observed and measured conditions on the site.

### 8.1. Procedure for Formal Inspection

The Contractor shall submit the following documents as indicated in Table 10.1 to the Engineer for scrutiny prior to the Formal Inspection after the receipt of notification of carrying out Formal Inspection. The Contractor shall provide sufficient time to the Engineer to allow full scrutiny of the submitted documents.

Table 10.1 List of Documents for Formal Inspection

Appendices	Names of Documents	Mandatory Submission	Submission, if requested by the Engineer
1	Fence Daily Voltage Reporting Sheet	○	
2	Fence Maintenance Report		○
3	Vegetation Control Sheet		○
4	Defects Detection/Rectification Record Form	○	
5	Daily Work Record Form	○	

6	Daily Inspection/Record Form	○	
7	Monthly Photo Records		○
8	Incident Condition & Activity Reports		○
9	Payment Reduction Calculation Table	○	

The criteria of each Condition and functional levels shall be checked jointly by the Engineer at sections selected by the Engineer based on visual appearance. The Engineer shall be the sole judge of compliance. If a specified criterion is not met, the one-kilometre section in which the deficit occurs will be judged non-compliant in accordance with the Self-Inspection Result Record Form.

The Engineer shall prepare a brief Memorandum describing (i) the general circumstances of the site visit, including date, fence sections visited, persons present, etc., (ii) any non-compliance which may have been detected, and (iii) the time granted by the Engineer to the Contractor to remedy the detected defects.

The results of Formal Inspection on Condition and Functional Levels will be recorded by the Engineer in this Memorandum. The Memorandum will state the type and location of any non-compliance detected, in particular those non-compliances already shown in the most recent Self Inspection Result Record Form provided by the Contractor as part of the Monthly Statement. For each individual case of non-compliance, the Engineer will determine a date by which the Contractor must have completed the necessary measures in order to remedy the cause of the non-compliance. A follow-up site visit is therefore necessary at the date fixed by the Engineer, or soon thereafter, in order to verify that the Contractor has indeed remedied the cause of non-compliance. If at the date indicated in the Memorandum, the Contractor has not remedied the cause for non-compliance, independent of the reason given for their failure to do so, the Contractor is subject to payment reduction in accordance with the relevant clauses of the Performance Specifications and GCC.

Based on the outcome of the Formal Inspection and subsequent remedies by the Contractor or otherwise, the Engineer will correct any possible errors or misrepresentations in the Contractor's Monthly Statement, countersign it and present it to the Employer for payment, and to the Contractor for information.

#### **9. Performance Monitoring by the Employer**

The Contractor shall acknowledge that the Employer encourages adoption of proactive approach by the Contractor on performing the Maintenance Services. To maintain such approach, the Employer shall have the power to entrust the Engineer to conduct monthly performance monitoring on the Contractor.



- 1) Performance monitoring will be conducted on condition and functional level compliance, self-control unit performance, work safety performance, performance on environment and social management, corrective order management and statutory compliance. The format of Monthly Evaluation Form is attached as Appendix 9, for the purpose of performance monitoring.
- 2) The result of performance monitoring of each month will be used for the evaluation of the Contractor at the end of each year. Evaluation of the Contractor shall be carried out by the Engineer using the Contract Evaluation Tally Sheet, which is attached as Appendix 10.

The total aggregate weighting of 100% is applied to 6 criteria in 1) above, with the weighting of 50% conditional and functional levels compliance, 20% on work safety performance, 0% on statutory compliance and the remaining criteria each weighing 10%.

- 3) The result of each month on each criterion will be evaluated either a pass or a failure. The tally will be made at the end of each month, collected to the end of the year and to arrive at the performance of the criterion as the percentage of pass attained during the year. The respective weight will be applied to arrive at the evaluation score, with the maximum score of 100 and the minimum score of 0. For statutory compliance, the evaluation score will not be tabulated, but a penalty of 20 will be imposed in case the Contractor faces violation on statutory compliance at least once in a year.

## **10. Handover Report**

Immediately prior to the completion of the contract, the Contractor shall prepare a Handover Report and submit to the employer. The purpose of the Handover Report is to provide a smooth transition to the next contract and ensure that the next contractor is aware of any outstanding issues. The Report will:

- (a) Summarize any unresolved issues;
- (b) Include the most recent complete set of data on the roads covered by the contract, and
- (c) Provide the following details as shall be agreed by the Engineer:
  - (i) A schedule of outstanding defects
  - (ii) Any unresolved issues, especially those that may impact on the next Contractor
  - (iii) Details of any sensitive issues
  - (iv) Any on-going special monitoring/maintenance needs.

## **BILL OF QUANTITIES**

**1.PREAMBLE TO BILL OF QUANTITIES**

**2. BILL OF QUANTITIES FOR REHABILITATION WORKS**

**3. BILL OF QUANTITIES FOR PBC MAINTENANCE SERVICES**

**4. BILL OF QUANTITIES FOR EMERGENCY WORKS**

**5. SUMMARY OF BILL OF QUANTITIES**

## **1. PREAMBLE TO BILL OF QUANTITIES**

- a) The Bill of Quantities shall form part of the Contract Documents and is to be read in conjunction with the Instructions to Tenderers, General Conditions of Contract (GCC), Particular Conditions of Contract (PCC), Specifications and Drawings.
- b) The brief description of the items in the Bill of Quantities is purely for the purpose of identification, and in no way modifies or supersedes the detailed descriptions given in GCC, PCC and Specifications for the full direction and description of the Works and Maintenance Services.
- c) The quantities set forth in the Bill of Quantities for the Works are estimated and provisional, representing substantially the Works to be carried out, and are given to provide a common basis for tendering and comparison of Tenders. There is no guarantee to the Contractor that he will be required to carry out all the quantities of Works indicated under any one particular item or group of items in the Bill of Quantities. The basis of payment shall be the Contractor's rates and the quantities of Works actually done in fulfilment of his obligation under the Contract.
- d) The prices and unit rates in the Bills of Quantities are to be the full and all-inclusive value of the work described under the items, including all costs and expenses which may be necessary and all general risks, liabilities and obligations set forth or implied in the documents on which the tender is based. All duties, taxes and other levies payable by the Contractor under the Contract, or for any other cause prior to the deadline for submission of tenders, shall be included in the rates and prices and the total Tender Price submitted by the tenderer.
- e) Each price or unit rate inserted in the Bills of Quantities should be a realistic estimate for completing the activity or activities described under that particular item and the tenderer is advised against inserting a price or rate against any item contrary to this instruction.
- f) Every rate entered in the Bills of Quantities, whether or not such rate is associated with a quantity, shall form part of the Contract. The Employer shall have the right to call for any item of work contained in the Bills of Quantities, and such items of work to be paid for at the rate entered by the tenderer and it is the intention of the Employer to take full advantage of unbalanced low rates.

- g) The prices and rates inserted in the Bills of Quantities will be used for valuing work executed, and the Engineer will measure the whole of the Works executed in accordance with this Contract. The Maintenance Services will not be measured. However, price reduction will be carried out for not achieving the defined Service levels as inspected by the Engineer under Formal Inspection.
- h) A price or rate shall be entered in ink against every item in the Bill of Quantities with the exception of items, which already have provisional sums, affixed thereto. The Tenderers are reminded that no “nil” or “included” rates or “lump-sum” discounts will be accepted. The rates for various items should include discounts if any. Tenderers who fail to comply will be disqualified.
- i) Provisional sums (including Day works) in the Bill of Quantities shall be expended in whole or in part at the discretion of the Engineer in accordance with Clause 58.2 and 52.4 of the GCC.
- j) The price and rates entered in the Bill of Quantities shall, except insofar as it is otherwise provided under the Contract, include all constructional plant to be used, labour, insurance, supervision, compliance, testing, materials, erection, maintenance or works, overheads and profits, taxes and duties together with all general risks, liabilities and obligations set out or implied in the Contract, transport, electricity and telephones, water, use and replenishment of all consumables, including those required under the Contract by the Engineer and his staff.

## 2. BILL OF QUANTITIES FOR REHABILITATION WORKS

<b>PERFORMANCE BASED MAINTENANCE OF 20KM OF WILDLIFE ELECTRIC FENCE AND ASSOCIATED WORKS IN MERU N. PARK- MERU COUNTY</b>					
<b>REHABILITATION WORKS (PROVISIONAL)</b>					
<b>Item No.</b>	<b>Description</b>	<b>Unit</b>	<b>Quantity</b>	<b>Rate (Ksh)</b>	<b>Amount (Ksh.)</b>
<b>A.</b>	<b>Preliminary and General Items</b>				
A1.	Provision for material testing	PC sum	PC		100,000.00
A2.	Provide and erect publicity signboard as per specifications	No	1		
A3.	Allow for off-road environmental mitigation	PC sum	PC		100,000.00
	<i>Sub - Total (A)</i>				
	<b>The following shall form costs for supply of materials and Rehabilitation Works for the Electric fence as per the drawings and specifications:</b>				
<b>B</b>	<b>EARTH WORKS</b>				
B1.	Fill in approved soft material in selected areas as directed	c.m.	1,000		
B2.	As item A2 for compaction of top 300mm in fills to 100% MDD (ASHTO T99) in areas as directed	c.m.	2,000		
	<b>Sub - Total (B)</b>				

<b>D.</b>	<b>FENCE WORKS</b> <b>Note: Test certificates for the materials shall be submitted and samples subjected for verification tests</b>	<b>Unit</b>	<b>Quantity</b>	<b>Rate (Ksh)</b>	<b>Amount (Ksh)</b>
D1.	Line Posts	Pc	200		
D2.	Strainer Posts	Pc	100		
D3.	2.5mm High Tensile Wire (HTS)	Roll	30		
D4.	4.0mm Soft wire	L.M.	500		
D5.	Barbed Wire	Roll	2		
D6.	2" Staple U - Nails	Kg	30		
D7.	Straight Nails	Kg	30		
D8.	Earth Pegs	Pc	6		
D9.	Warning signs	Pc	12		
D10.	W-Insulators.	No.	100		
D11.	Strain End insulators	No.	100		
D12.	Joint Clamps	Pc	100		
D13.	Reel Insulator	No.	100		
D14.	Mains Energizer – option 1	Pc	1		

D15.	Energizer 16 Joules stored Energy (Solar) – option 2	Pc	1		
D16.	140W Solar Panel	Pc	1		
D17.	100 Ah Solar battery	Pc	1		
D18.	Charge regulator	Pc	1		
D19.	2.5mm dia. Under gate cable	Roll	1		
D20.	Flood gate controller	Pc	2		
D21.	Lightening Diverters/Arrestors	Pc	1		
D22.	Spring gate	Pc	2		
	Sub – Total (C)				
<b>E.</b>	<b><u>Drift construction</u></b>				
E1.	Provide and place 2x1x1 gabion boxes	M <sup>2</sup>	90		
E2.	Provide and place rock fill to gabions	M <sup>3</sup>	200		
E3.	Provide and place class 25/20 concrete	M <sup>3</sup>	20		
E4.	Provide and place BRC A142 mesh reinforcement	M <sup>2</sup>	160		
E5.	Allow a PC sum of Kshs 150,000 for HIV Aids Awareness and prevention campaign	PC Sum			
	Sub – Total (D)				
	<b>Total Carried Forward to Summary Page – (A)+(B)+(C)+(D)</b>				

**3. BILL OF QUANTITIES FOR  
PBC MAINTENANCE SERVICES**

<b>PERFORMANCE BASED MAINTENANCE OF 20KM OF WILDLIFE ELECTRIC FENCE AND ASSOCIATED WORKS IN MERU N. PARK-</b>					
<b>Item</b>	<b>Description of Work Item</b>	<b>Unit</b>	<b>Nominal Quantity</b>	<b>Rate</b>	<b>Amount</b>
	<b>Site Clearance / Vegetation Control</b>				
A.	Light Bush Clearing	M <sup>2</sup>	120,000		
B.	<u>Clearing of obstruction:</u>	No.	100		
	Cut and remove fallen trees girth not exceeding 400mm, and remove debris away fence alignment				
	<b><u>Light Grading and Spot Patching:</u></b>				
	<b><u>Performance contract</u></b>				
D.	Contractor's Self Control Unit	Months	1		
	<b>Total PBC Works</b>				
	<b>Duration of the PBC Contract 24 Months</b>		<b>Cost/Month @ Ksh. Approx.</b> .....		
	<b>Length of Fence 20Km</b>		<b>Cost/Month/Km</b>		



4. BILL OF QUANTITIES FOR EMERGENCY WORKS

<b>PERFORMANCE BASED MAINTENANCE OF 20KM OF WILDLIFE ELECTRIC FENCE AND ASSOCIATED WORKS IN MERU N. PARK.</b>					
<b>EMERGENCY WORKS (PROVISIONAL)</b>					
<b>Item</b>	<b>Description of Work Item</b>	<b>Unit</b>	<b>Quantity</b>	<b>Rate</b>	<b>Amount</b>
	<p><b>PLANT AND EQUIPMENT</b></p> <p>The rates included herein are to include all mobilization, operational and maintenance costs, fuel, oil, grease, operator charges, wages, supervision, overheads and profits. Only time employed upon the work will be measured and the rates shall include idle time spent travelling and overtime. All items of the plants must be priced.</p>				
A.	<p><b>Motor Graders complete with scarified</b></p> <p>A – 80 – 110 kw rated flywheel power</p>	Hr.	2.00		
B.	90 Hp tractor with trailer	Hr.	2.00		

C.	Diesel Concrete Vibrator- Poker Type	Hr.	2.00		
D.	Tipper (dump) Truck (7 tons gross weight)	Hr.	2.00		
E.	Van, pick-up or similar utility vehicle				
	a-up to 1.0t carrying capacity	Hr.	2.0		
			0		
F.	<b>Water bowser – Self Propelled</b>	Hr.			
	a-4551-7000-liter capacity		2.00		
	<b>Totals carried forward to the Next Page</b>				

Item	Description of Work Item	Unit	Quantity	Rate	Amount
	<b>Totals carried forward from previous Page</b>				
	<b>Labor:</b>				
A.	Note The rate included herein shall include all costs for labor, as well as overtime, travelling time and cost of accommodation, social security contributions, use and maintenance of small tools of trade, supervision insurance, overheads, profits and any other cost.				
	a-Laborer	Hr.	8.00		
	b-Artisan	Hr.	8.00		
	c-Plant Operator	Hr.	8.00		
	d-Driver	Hr.	8.00		
	e-Foreman	Hr.	8.00		

**MATERIALS**

**All items of materials must be priced in accordance with the requirements of Detailed Specifications for Construction**

**D. FENCE MATERIALS**

D1.	Line Posts	Pc	200
D2.	Strainer Posts	Pc	100
D3.	2.5mm High Tensile Wire (HTS)	Roll	30
D4.	4.0mm Soft wire	L.M.	500
D5.	Barbed Wire	Roll	1
D6.	2" Staple U - Nails	Kg	30
D7.	Straight Nails	Kg	30
D8.	Earth Pegs	Pc	6
D9.	Warning signs	Pc	12
D10.	W-Insulators.	No.	100
D11.	Strain End insulators	No.	100
D12.	Joint Clamps	Pc	100
D13.	Reel Insulator	No.	100
D15.	Mains Energizer – option 1	Pc	1
D16.	Energizer 16 Joules stored Energy (Solar) – option 2	Pc	1
D17.	140W Solar Panel	Pc	1
D18.	100 Ah Solar battery	Pc	1
D19.	Charge regulator	Pc	1
D20.	2.5mm dia. Under gate cable	Roll	1
D21.	Flood gate controller	Pc	3
D22.	Lightening Diverters/Arrestors	Pc	1
D23.	Spring gate	Pc	5
B.	Ordinary Portland cement	kg	200
C.	<b>Aggregates for concrete</b>		

a) Fine	c.m.	20		
b) Coarse	c.m.	20		
<b>Grand Total For emergency Works</b>				

**Summary of Bill of Quantities**

<b>Description</b>	<b>Amount (in Figures) Kshs</b>
(i) Performance Based Maintenance Works in an amount of <i>[amount in words]</i> ..... <b>Unit Price Per Kilometre Per Month</b> multiply by Number <b>of Months X Total Fence Length (Kms)</b> ..... <i>Kshs/Km/Month x ...24.....Months x ...20.....Km</i>	
(ii) Rehabilitation Works in an amount of <i>[amount in words]</i> .....	
(iii) Provisional sum for Emergency Works in an amount of <i>[amount in words]</i> .....	

<b>(A.) Sub TOTAL 1 = (i) + (ii) + (iii)</b>	
<b>(B). Add Contingency (5%)</b>	
<b>(C) Total Cost Estimate for PBC (A+B)</b>	

**Appendix A: Performance Standards for the Electric Fence**  
**A. CONDITION LEVELS**

Condition criteria		Required Condition	RESPONSE TIME	TOLERANCE
Check Element	Defect		<< x hours>> means "within x hrs./days/wks."	
<b>I) Structural soundness</b>				
Line, Corner assemblies and strainer posts	Leaning	The posts must be founded with concrete and remain vertically straight, general configuration including soft wires must comply with the design requirements and all materials must comply with specifications	<< 24 hrs.>>	No tolerance permitted
	Split ends		<<24 hrs.>>	No tolerance permitted
	Termite infested	No termite infestation	<<5 Days>>	The permitted level of

				tolerance of not more than 5% of the total surface area
HTS wires, Soft Wires and Mesh	Slack, brokages, wrong knots	No slacks, no breakages, strong knots	<<24 hrs.>>	No tolerance permitted
<b>II) Control of Vegetation growth</b>				
Along fence line	Overgrowth	No vegetation	<<24 hrs.>>	No tolerance permitted
<b>III) Service Road</b>				
Pass ability of the road	Impassable	Passable at all times	<<24 hrs.>>	No tolerance permitted
Drainages	Blocked/clogged	Allow free flow of storm water	<<24 hrs.>>	No tolerance permitted
<b>IV) Fire Break</b>				
Along Fence line	Vegetation growth	Controlled growth	<<24 hrs.>>	No tolerance permitted

## B. FUNCTIONAL LEVELS

Condition criteria		Required Condition	RESPONSE TIME	TOLERANCE
Check Element	Defect		<< x hours>> means "within x hrs./days/wks."	
<b>I) Voltage Reading</b>				
Voltmeter Reading between Live (+) and Neutral (-)	Less than 5KV	Min. Reading = 5KV	<< 24 hrs.>>	No tolerance permitted
Hatari Signs	Invisible, missing	Material to comply with specifications	<< 24 hrs.>>	No tolerance permitted
<b>II) Security Management System</b>				
Central Command Room displays	No real time relay	Real time	<<24 hrs.>>	No tolerance permitted

**Appendix 1: Fence Daily Voltage Reporting Sheet**

**STATION:**

\_\_\_\_\_

**FENCE NAME:**

\_\_\_\_\_

**FENCE LENGTH:**

\_\_\_\_\_

**MONTH:**

	<b>VOLTAGE</b>	<b>VOLTAGE</b>	<b>AVERAGE READING</b>	<b>CAUSE OF VOLTAGE DROP</b>	<b>VOLTAGE</b>	<b>ACTION</b>
<b>DATE</b>	<b>6:00 AM</b>	<b>4:00 PM</b>				
01/..... /.....						
02/..... /.....						
03/..... /.....						
04/..... /.....						
05/..... /.....						
06/..... /.....						
07/..... /.....						
08/..... /.....						
09/..... /.....						
10/..... /.....						



11/..... /.....					
12/..... /.....					
13/..... /.....					
14/..... /.....					
15/..... /.....					
16/..... /.....					
17/..... /.....					
18/..... /.....					
19/..... /.....					
20/..... /.....					
21/..... /.....					
22/..... /.....					
23/..... /.....					
24/..... /.....					
25/..... /.....					
26/..... /.....					

27/..... /.....					
28/..... /.....					
29/..... /.....					
30/..... /.....					
31/..... /.....					

**Comments**

**Prepared by**  
**Signature**

-----  
-----

**Checked by**  
**Signature**

-----  
-----

**Appendix 2: Fence Maintenance Report**

**FENCE MAINTENANCE  
REPORT**

**FENCE  
LOCATION**

\_\_\_\_\_

**SOURCE OF POWER**

\_\_\_\_\_

FENCE NAME \_\_\_\_\_

LENGTH \_\_\_\_\_

FENCE \_\_\_\_\_

DESIGN \_\_\_\_\_

YEAR BUILT \_\_\_\_\_

REPORTING PERIOD \_\_\_\_\_

DATE	FAULT AND REPAIR														
	Short circuiting		Vandalism	Animal breakin g	Vegetation growth cutting (Underneath Elec. Fence)		Equipmen t fault	Rain damag e	Materials			Transport		Labor	
	KM	Solved			From KM	To KM			Type	Qty	Cost	Dist. KM	Fuel LTR	Cost	Man-days

Prepared by \_\_\_\_\_

Checked by \_\_\_\_\_

Sign: \_\_\_\_\_

Sign: \_\_\_\_\_

Date \_\_\_\_\_

Date \_\_\_\_\_



**Appendix 4: Defect Detection/ Rectification Record Form**

No	Detection (to be filled by SCU or PM)			Rectification (to be filled by EXU)		Remark
	Date	Location	Description	Date	Compliance (Yes/No)	
1						
2						
3						
4						
5						
6						
7						
8						
9						
10						
11						
12						
13						
14						
15						
16						

17							
18							
19							
20							
21							
22							
23							
24							
25							
26							
27							
28							
29							
30							
31							
32							
33							
34							
35							
36							
37							
38							
39							
40							
41							
42							
43							
44							



Materials Delivered to Site			Materials Removed from Site		
Description	Quantity	Photo No,	Description	Quantity	Photo No,
<b>Admission</b>					
Personal	Name		Sign	Date	
Self-Control Unit					
Engineer					

Appendix 6: Daily Inspection/Patrol Record

Basic Information			
Authority			
Contractor			
Project			
Fence Name/Chainage			
Type of Fence		Standard Performance Level	

**Patrol**

Date		Weather	
------	--	---------	--



**Cleanliness/Obstacles**

Chainage	Time		Remarks	Photo No.
	Detection	Removal		

**Any other activities undertaken**

Chainage	Objects, Condition, other information	Photo No.

**Admission**

Personal	Name	Sign	Date
Self-Control Unit			
Engineer			

## Appendix 7: Monthly Photo Record

**Basic Information**

Authority	
Contractor	

Project			
Fence Name/Chainage			
Fence Type		Standard Performance Level	

No,	DATE	DATE
Photo	Photo file size: less than 300kB	Photo file size: less than 300kB
Remarks		
No,	DATE	DATE
Photo	Photo file size: less than 300kB	Photo file size: less than 300kB
Remarks		
No,	DATE	DATE

Photo	Photo file size: less than 300kB	Photo file size: less than 300kB
Remarks		

## Appendix 8: Incident Condition and Activity Report

<b>Basic Information</b>			
Road Authority			
Contractor			
Project			
Fence Name/Chainage			
Fence Type		Standard Performance Level	

<b>Incident Notification</b>	Caller	Phone No,
Date/Time /Chainage or Location		
Information Resource	Authority, Police, Engineer, Others ( )	
Mature of Incident		
Location of Incident		
Condition of Accident Vehicles		
Number/Conditions of injured People		

### **Description**

--

--

<b>Site Condition (Any Fence asset damaged by the accident)</b>				Photo No,
Assets	Damage condition			



### Appendix 9: Payment Reduction Calculation Table

Project					Contract Period	
Authority				Contractor		
Fence Name/Type/Chainage/(j) Length	Fence:			Type:	Length (Km):	
Statement Month/Year and Elapse of Month					Year:	

Contract Due Amount of the Month (x)

**KSH.**

Performance Standards		(a) Contract Fence Length (Km)	(b) Required Target	(c) = (a)x(b) Target Length (Km)	(d) = (a)-(c) Exemption Length (Km)	(e) Non-Compliant Length (Km)	(f) = (e) - (d) (>=0) Adjusted Non-Compliant Length (Km)	(f)/(c) NON-Compliant Rate	(g) Reduction Weight	(h) = (f)x(g) Reduction Rate (%)	(i)= (c)x(h) Reduction Length (Km)
Standard	Standard Scope										
Documentation			100%						4.0%		
A. Condition	1. Structural Soundness		100%						40.0%		
	2. Control of vegetation growth		100%						24.0%		
	3. Maintainance of		100%						42.0%		

	Service Road, Fire Break and drainage		%						%		
			100 %								
B. Functional	4. Voltage Reading		100 %						40.0 %		
	5. Security Management System		100 %						50.0 %		
									Total (j) = 200%		

Required Target		
Elapse of Month	A. Condition	B. Functional
1	50%	50%
2	100%	100%
3	100%	100%
4	100%	100%
5	100%	100%

**Calculation of the Payment Amount for the Month**

<b>Contract Due Amount for the Month</b>	<b>KSH</b>		(x)
<b>Reduction Rate</b>	%		(i)
<b>Reduction Amount</b>	KSH		(z) = (x) x (i)
<b>Payment Amount for the Month</b>	KSH		(y) = (x) - (z)



# **DRAWINGS**

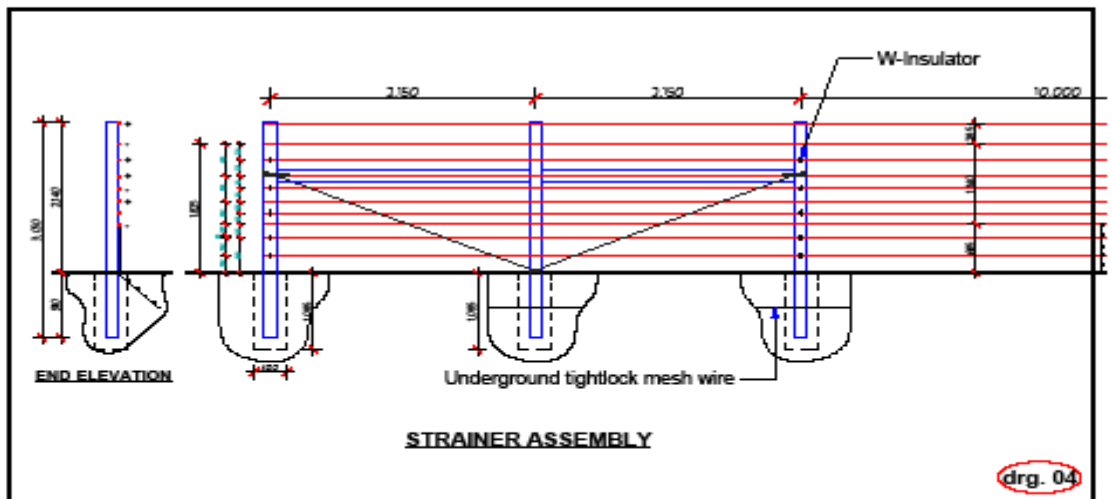
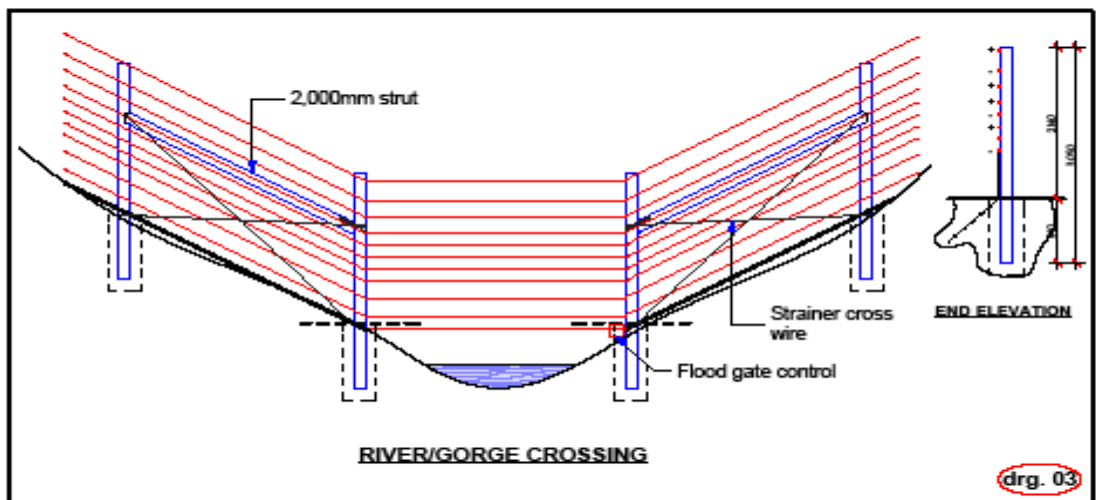
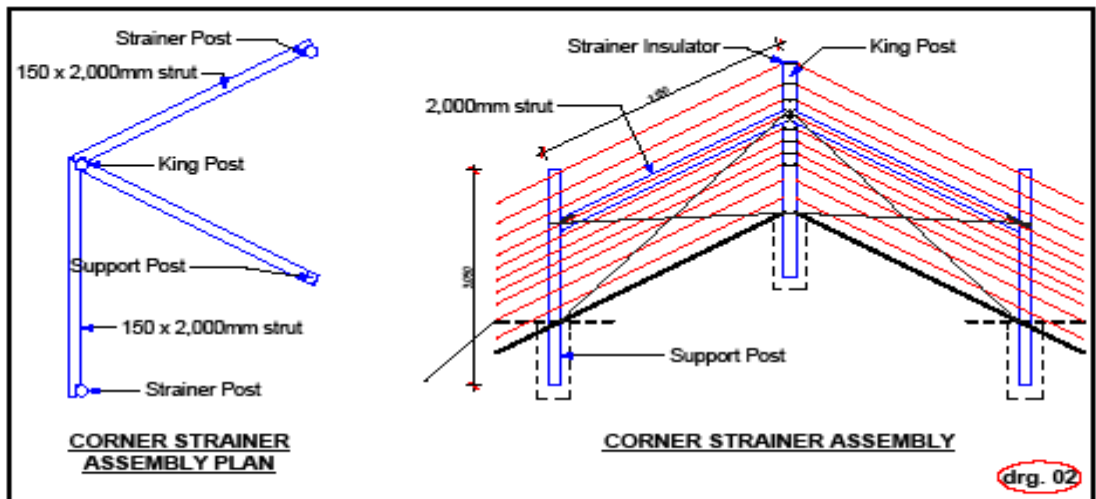

**Note: No. of strands are 8, NOT 10**

